

# MINIMUM REQUIREMENTS AND GUIDELINES FOR THE EXTERIOR BUILDING ENVELOPE

State of Wisconsin  
Department of Administration  
Division of Facilities Development

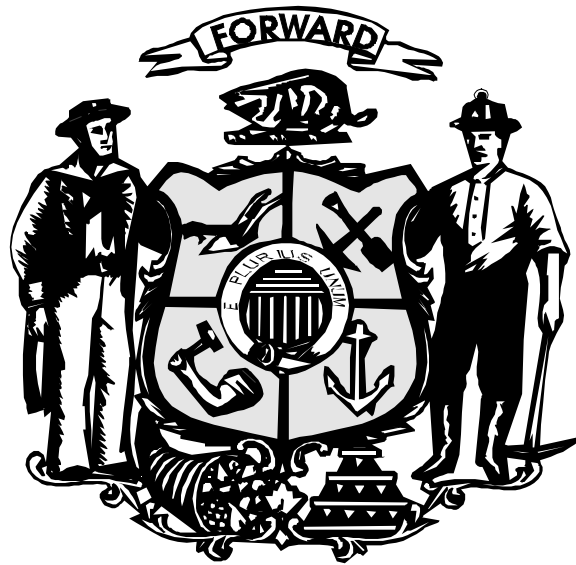

FEBRUARY, 2001

# **MINIMUM REQUIREMENTS AND GUIDELINES FOR THE EXTERIOR BUILDING ENVELOPE**

## **INTRODUCTION**

The minimum requirements are to be complied with, as applicable, on all Wisconsin state-owned building projects.

The intent of these minimum requirements and guidelines is to obtain an exterior building envelope that is structurally sound, watertight, cost effective, maintainable and energy efficient. For numerous reasons, state-owned buildings are typically planned for a life expectancy greater than that proposed/anticipated in the private sector. These minimum requirements are not all-encompassing, but they represent design, materials, techniques and workmanship that have proven successful on building construction in the region of the Upper Great Lakes.

The design and construction of the exterior building envelope should avoid systems and components that have not had a minimum five year history of successful use. The State does not want to spend extra money to buy a problem, which then costs additional money to fix.

These directions are not intended to stifle creativity or innovations. Architects and Engineers are encouraged to submit a written request for a waiver of specific minimum requirements or time-in-use limitations, along with justification, to the Division of Facilities Development where circumstances warrant such action. A written response with appropriate decision will be provided through the appropriate exterior envelope team member.

Updates to this document and other standards and guides may be found at the Division of Facilities Development main page, located at <http://www.doa.state.wi.us/dfd/dfdmain.asp>. If there are questions on any portion of this document or a need to discuss its importance/relevancy, contact Lynn R. Lauersdorf, Deputy Director of the Bureau of Architecture and Project Management, by telephone: 608/266-1438; via facsimile: 608/267-2710; or via e-mail: [lynn.lauersdorf@doa.state.wi.us](mailto:lynn.lauersdorf@doa.state.wi.us).

**MINIMUM REQUIREMENTS AND GUIDELINES  
FOR THE EXTERIOR BUILDING ENVELOPE**

**CONTENTS**

**EXTERIOR WALLS**

Pages

<b>I.</b>	<b>Minimum Requirements for Exterior Walls on Major Projects Involving New Buildings</b>	
A.	Design .....	I. 1-2
1.	General Design to be Provided .....	I. 1
2.	Design Details to be Provided When Applicable.....	I. 1
3.	Design Details to be Avoided .....	I. 1-2
B.	Material .....	I. 2
1.	Face Brick .....	I. 2
2.	Architectural Precast Concrete.....	I. 2
3.	Exterior Insulation and Finish System .....	I. 2
4.	Mortar .....	I. 2
5.	Sealant.....	I. 2
C.	Construction.....	I. 2
1.	Construction Practices to be Provided When Applicable .....	I. 2
2.	Construction Practices to be Avoided.....	I. 2
<b>II.</b>	<b>Guidelines for Design and Building of Masonry Resistant to Wind-Driven Rain</b>	<b>II. 1-6</b>
A.	Introduction.....	II. 1
B.	Wall Leaks .....	II. 1-3, & 6
C.	Wall Types .....	II. 3-4
D.	Conclusions.....	II. 5

<b>III.</b>	<b>Guidelines for Movement Joints in Exterior Walls of New Buildings .....</b>	<b>III. 1-22</b>
A.	Summary .....	III. 1
B.	Movement .....	III. 1-2
C.	Movement Joints .....	III. 3
D.	Vertical Movement Joints .....	III. 3-6
E.	Horizontal Movement Joints .....	III. 6-8
F.	Special Movement Joints .....	III. 8-9
G.	Conclusion .....	III. 9
H.	List of Attachments .....	III. 9
<b>IV.</b>	<b>Guidelines for Exterior Wall Flashing.....</b>	<b>IV. 1-5</b>
<b>V.</b>	<b>Guidelines for Parapet Walls.....</b>	<b>V. 1</b>
<b>VI.</b>	<b>Guidelines for Exterior Garden, Planter and Wing Walls .....</b>	<b>VI. 1</b>
<b>VII.</b>	<b>Guide Specification for Sample Wall/Panel of New Masonry .....</b>	<b>VII. 1</b>
<b>VIII.</b>	<b>Guide Specification for Construction of Exterior Rain Screen Wall.....</b>	<b>VIII. 1-2</b>
<b>IX.</b>	<b>Guide Specification for Laying and Cleaning of New Masonry.....</b>	<b>IX. 1</b>
<b>X.</b>	<b>Minimum Requirements for Quality of Exterior Face Brick Masonry Units on Projects with More than 15,000 New Face Brick Required.....</b>	<b>X. 1</b>
<b>XI.</b>	<b>Guidelines for Selection of Face Brick Masonry Units.....</b>	<b>XI. 1-2</b>
<b>XII.</b>	<b>Guide Specification for Face Brick Masonry Units on Projects with More Than 50,000 New Face Brick Required .....</b>	<b>XII. 1-3</b>
<b>XIII.</b>	<b>Minimum Requirements for Architectural Precast Concrete .....</b>	<b>XIII. 1</b>
<b>XIV.</b>	<b>Minimum Requirements for Exterior Insulation and Finish Systems (EIFS)</b>	<b>XIV. 1</b>
<b>XV.</b>	<b>Guide Specification for Mortar .....</b>	<b>XV. 1-2</b>
<b>XVI.</b>	<b>Minimum Requirements for Sealants in Exterior Walls of New Buildings ..</b>	<b>XVI. 1-3</b>

<b>XVII. Commentary on Minimum Requirements for Exterior Walls on Major Projects Involving New Buildings .....</b>	<b>XVII. i &amp; 1-53</b>
A. Design .....	XVII. 1-40
1. General Design to be Provided .....	XVII. 1-8
a. Rain screen principle.....	XVII. 1-3
b. Masonry back-up.....	XVII. 1 & 5
c. Protected (unexposed) frame .....	XVII. 5
d. Cast-in-place concrete foundations.....	XVII. 6
e. Air/vapor barrier on warm side of wall.....	XVII. 6-7
f. Rigid polystyrene insulation (extruded preferred) in portion of cavity.....	XVII. 7-8
2. Design Details to be Provided When Applicable.....	XVII. 8-35
a. Adequate movement joints in masonry.....	XVII. 8
b. Base support of exterior masonry wythe on foundation wall ledge.....	XVII. 8-10
c. Masonry starting above grade .....	XVII. 8 & 11
d. Mortar-free, open head joints at masonry weight supports on 24" centers max. (32" centers max. when 16" long units are utilized) .....	XVII. 11
e. Half-round tubes at counterflashing Receivers on 24" centers max. ....	XVII. 11-12
f. Positive lateral support for masonry elements at the top and bottom, and sides when feasible .....	XVII. 13 & 14
g. Positive air seal at juncture of masonry back-up with underside of roof system, and the wall cavity sealed off at all masonry openings .....	XVII. 13
h. Positive fastening of rigid insulation to masonry back-up in cavity by mechanical and adhesive means to insure insulation is permanently secured.....	XVII. 15
i. Back-up masonry and any other air or vapor barrier sealed at perimeter and penetrations with appropriate sealant.....	XVII. 15
j. Overhangs on copings, caps and sills, with drips and flashing directly below.....	XVII. 15-21
k. Corrosion-resistant metal flashings at masonry weight supports and the head and sill of all wall openings, exposed a minimum of 3/4" and turned down to serve as a drip.....	XVII. 21-32
l. Three-side rod (truss-type preferred) hot-dip galvanized, 3/16" continuous joint wall reinforcing on 16" centers max., discontinuous at movement joints.....	XVII. 33-35
m. Dovetail anchor slots provided in concrete frame to receive ties for masonry .....	XVII. 35
n. Tooled, concave mortar joints on all vertical surfaces exposed to weathering.....	XVII. 35

3.	Design Details to be Avoided .....	XVII. 35-40
a.	Dry-pack concrete trim elements .....	XVII. 35
b.	Common clay brick for back-up .....	XVII. 35
c.	Conventional concrete masonry exposed directly to the elements .....	XVII. 36
d.	Water resistant surface treatments on exterior masonry ...	XVII. 36
e.	Parapets .....	XVII. 36-37
f.	Outside garden, planter and wing walls .....	XVII. 37-39
g.	Projections, recesses or other ornamentation in masonry without permanent wash surfaces or flashing coverings .....	XVII. 39
h.	Unit masonry caps and sills .....	XVII. 39
i.	Soldier and header course masonry and decorative masonry panels.....	XVII. 40
B.	Material .....	XVII. 40-46
1.	Face brick .....	XVII. 40-42
2.	Architectural precast concrete.....	XVII. 42
3.	Exterior insulation and finish system.....	XVII. 42-43
4.	Mortar .....	XVII. 43-44
5.	Sealant.....	XVII. 44-46
C.	Construction .....	XVII. 47-53
1.	Construction Practices to be Provided When Applicable .....	XVII. 47-51
a.	Approval of samples before starting substantial work.....	XVII. 47-51
b.	Masonry laid with clean faces and faces kept clean.....	XVII. 47
c.	Clean cavities (2" min. preferred) in walls .....	XVII. 51
d.	Movement joints in clay products masonry free of mortar	XVII. 51
e.	Caulking of movement joints in clay products masonry during warm weather .....	XVII. 51
2.	Construction Practices to be Avoided.....	XVII. 51-53
a.	Chemical or harsh physical cleaning of masonry.....	XVII. 51-53
b.	Laying masonry in winter without temporary enclosures and heat .....	XVII. 53

## DRAWING/TABLE LISTING

Results of Air Pressures on Building Envelopes .....	II. 6
Summary for Movement Joints in Exterior Walls of New Buildings.....	III. 1
Causes and Types of Movements for Building Materials.....	III. 10
Coefficients of Movement of Masonry Materials.....	III. 11
University Dormitory - Results of No Movement Joints.....	III. 12
Spacing of Vertical Movement Joints.....	III. 13
Vertical Movement Joint Detail.....	III. 14
Cause of Cracking at Corners.....	III. 15
Typical Wall Section Detail.....	III. 16
Shelf Angle Detail.....	III. 17
Shelf Angle Detail (Option A).....	III. 18
Shelf Angle Detail (Option B).....	III. 19
Shelf Angle Detail (Option C).....	III. 20
Typical Roof Edge Detail (Stone or Concrete Cap).....	III. 21
Exterior Wall/Cross Wall Juncture Detail.....	III. 22
Flashing Internal/External Corners.....	IV. 2
Flashing End Dam.....	IV. 3
Flashing End Dam.....	IV. 4
Proper Sealant Joint Configuration.....	XVI. 2
Vertical Flashing Closure Detail.....	XVII. 2
Corner Wall Closure Detail.....	XVII. 3
Intermittent Wall Closure Detail.....	XVII. 4
Typical Foundation Ledge Detail (Option A).....	XVII. 9
Typical Foundation Ledge Detail (Option B).....	XVII. 10
Drainage at Counterflashing Receiver.....	XVII. 12
Block/Spandrel Connection Options.....	XVII. 14
Sleeve for Dowel Penetrating Flashing.....	XVII. 17
Wall Cap Detail.....	XVII. 18
Aluminum Sill Cover.....	XVII. 19
Typical Roof Edge Detail (Metal Cap Flashing).....	XVII. 20
Typical Sill Detail.....	XVII. 23
Flashing Connection at Shelf Angle.....	XVII. 24
Common Flashing Problems Being Experienced.....	XVII. 26
Throughwall Flashing Detail Juncture at Low Roof to Wall Above.....	XVII. 27
Throughwall Flashing Detail Juncture at Low Roof to Wall Above.....	XVII. 28
Throughwall Flashing Detail Juncture at Low Roof to Wall Above.....	XVII. 29
Throughwall Flashing Problem Juncture at Low Roof to Wall Above.....	XVII. 30
Flashing Stepping Down.....	XVII. 31
Flashing Stepping Down.....	XVII. 32
Truss Versus Ladder Reinforcing.....	XVII. 34
Garden Wall Detail.....	XVII. 38

# MINIMUM REQUIREMENTS FOR EXTERIOR WALLS ON MAJOR PROJECTS INVOLVING NEW BUILDINGS

## A. DESIGN

### 1. General Design to be Provided:

- a. Rain Screen principle. (See Guidelines for Designing and Building of Masonry Resistant to Wind Driven Rain, Pages II. 1-6.)
- b. Masonry back-up.
- c. Protected (unexposed) frame.
- d. Cast-in-place concrete foundations.
- e. Air/vapor barrier on warm side of wall.
- f. Rigid polystyrene insulation (extruded preferred) in portion of cavity.

### 2. Design Details to be Provided when Applicable:

- a. Adequate movement joints in masonry. (See Guidelines for Movement Joints in Exterior Walls of New Buildings, Pages III. 1-22.)
- b. Base support of exterior masonry wythe on foundation wall ledge.
- c. Masonry starting above grade.
- d. Mortar-free, open head joints at masonry weight supports on 24" centers max. (32" centers max. when 16" long units are utilized).
- e. Half-round tubes at counterflashing receivers on 24" centers max.
- f. Positive lateral support for masonry elements at the top and bottom, and sides when feasible.
- g. Positive air seal at juncture of masonry back-up with underside of roof system, and the wall cavity sealed off at all masonry openings.
- h. Positive fastening of rigid insulation to masonry back-up in cavity by mechanical and adhesive means to insure insulation is permanently secured.
- i. Back-up masonry and any other air or vapor barrier sealed at perimeter and penetrations with appropriate sealant.
- j. Overhangs on copings, caps and sills, with drips and flashing directly below.
- k. Corrosion-resistant metal flashings at most masonry weight supports and the head and sill of all wall openings, exposed a minimum of 3/4" and turned down to serve as a drip. (See Guidelines for Exterior Wall Flashing, Pages IV. 1-5.)
- l. Three-side rod (truss-type preferred) hot-dip galvanized, 3/16" continuous joint wall reinforcing on 16" centers max., discontinuous at movement joints.
- m. Dovetail anchor slots provided in concrete frame to receive ties for masonry.
- n. Tooled, concave mortar joints on all vertical surfaces exposed to weathering.

### 3. Design Details to be Avoided:

- a. Dry-pack concrete trim elements.
- b. Common clay brick for back-up.
- c. Conventional concrete masonry exposed directly to the elements.
- d. Water-resistant surface treatments on exterior masonry.
- e. Parapets. (See Guidelines for Parapet Walls, Page V. 1.)
- f. Exterior garden, planter and wing walls. (See Guidelines for Exterior Garden, Planter and Wing Walls, Page VI. 1.)



- g. Projections, recesses or other ornamentation in masonry without permanent wash surfaces or flashing coverings.
- h. Unit masonry caps and sills.
- i. Soldier and header course masonry and decorative masonry panels.

## B. MATERIAL

- 1. Face brick (See Minimum Requirements for Quality, Page X. 1; Guidelines for Selection, Pages XI. 1-2; and Guide Specification, Pages XII. 1-3.)
- 2. Architectural precast concrete (See Minimum Requirements, Page XIII. 1.)
- 3. Exterior insulation and finish system (See Minimum Requirements, Page XIV. 1.)
- 4. Mortar (See Guide Specification, Pages XV. 1-2.)
- 5. Sealant (See Minimum Requirements, Pages XVI. 1-3.)

## C. CONSTRUCTION

- 1. Construction Practices to be Provided When Applicable:
  - a. Approval of samples before starting substantial work. (See Guide Specification for Sample Wall/Panel of New Masonry, Page VII. 1.)
  - b. Masonry laid with clean faces and faces kept clean. (See Guide Specification for Laying and Cleaning of New Masonry, Page IX. 1.)
  - c. Clean cavities (2" min. preferred) in walls. (See Guide Specification for Construction of Exterior Rain Screen Wall, Pages VIII. 1-2.)
  - d. Movement joints in clay products masonry free of mortar.
  - e. Caulking of movement joints in clay products masonry during warm weather.
- 2. Construction Practices to be Avoided:
  - a. Chemical or harsh physical cleaning of masonry. (See Guide Specification for Laying and Cleaning of New Masonry, Page IX. 1.)
  - b. Laying masonry in winter without temporary enclosures and heat.

# **GUIDELINES FOR DESIGN AND BUILDING OF MASONRY RESISTANT TO WIND- DRIVEN RAIN**

## **A. INTRODUCTION**

All components of buildings can be subject to problems. Exterior masonry walls are no exception. Design, material, procedure (construction practice or technique) and workmanship (craftsmanship) are all interrelated and very important, but proper details and their accomplishment in construction are the real keys to achieve success.

The overwhelming majority (about 90 percent) of all building problems are associated with water in some way. Excess water plays a predominant role in causing materials to deteriorate. Moisture may penetrate building enclosures in vapor, liquid or solid state and manifest itself in a multitude of forms. The ultimate hazard is freezing and thawing cycles with moisture present. Despite vast advances in building technology, the greatest problem with exterior wall systems remain rain penetration and its effects. This guide describes why walls leak and discusses the potential wall types, those which are good as well as those that cause concern.

## **B. WALL LEAKS**

Walls leak when three conditions exist simultaneously: (1) Rain water is on a wall; (2) Openings exist through which the rain water can pass; and (3) Forces are present to drive or draw the rain water inward. If any of these three essential conditions is eliminated, rain water will not penetrate the enclosure.

It is difficult and impractical to keep wind-driven rain off the exterior walls of a building. Overhangs, cornices, and solar shading can be effective in minimizing, but will not prevent, wetting of a wall. Thus, it should be expected that exterior walls will be covered by a film of water during a rainstorm and that this film thickens when rain flows down the building wall.

It is virtually impossible to build an exterior wall without any unintentional openings or leakage paths. Such openings, may be as pores, cracks, incompletely filled mortar joints, poorly bonded interfaces, or moving joints between elements or different materials. A typical masonry wall contains multiple apertures of various types and sizes yielding many joints between dissimilar materials prone to movement and joint failure. One square foot of brick masonry contains 6.75 modular brick, 6 lineal feet of mortar joint and 12 lineal feet of brick-mortar joint interface. For 20,000 square feet of wall surface, this equates to 135,000 modular brick, 22.7 miles of mortar joint and 45.5 miles of brick-mortar joint interface. Water can penetrate openings as small as 0.005 inches, which is just slightly more than the thickness of a sheet of bond paper.

Even if a good seal is achieved initially, odds are that the seal will deteriorate over time under the action of temperature, water, ultraviolet radiation and differential movement. For these reasons, a single 4-inch wythe of masonry conventionally laid up in the field, of and by itself, should not be expected to be watertight.

Forces acting on an exterior wall during a rainstorm that individually or in combination can contribute to rain penetration include: (1) raindrop momentum; (2) capillary suction; (3) air currents; (4) gravity; (5) external air (wind) pressure; and (6) internal building pressure.

- **RAINDROP MOMENTUM:** Under the influence of wind, raindrops can hit the wall of a building with such high velocity that their momentum carries them through any large openings in their path. If an opening is small, the raindrop will be shattered on impact, and only the smallest droplets will continue inward. If there is no through path, however, water cannot travel deeply into the wall by this means alone.
- **CAPILLARY SUCTION:** Fine capillaries, less than 0.005 inches, common to normal hard-fired clay brick or concrete, draw and hold a small volume of water with such high suction that they seldom allow water to penetrate. A greater volume of water, however, is held by the lower suction, large capillaries (0.005 inches and larger) such as are common for cracks and unbonded interfaces. Large capillaries are important contributors to the penetration problem when an additional wind force of even low magnitude is added.
- **AIR CURRENTS:** A substantial film of water can form and flow on a wall face. This water film generally increases in thickness toward the lower levels of a building due to rundown of rainwater on the wall. Air currents can increase downward velocity of flow, move a film laterally or even push water upward. These same air currents can also deposit snow into openings otherwise inaccessible to conventional wind driven rain.
- **GRAVITY:** Gravity acting on water on the wall surface, or in large capillaries, will pull the water through any passages that lead downward. Water running down the sides of vertical cracks or open joints can be diverted inward by surface irregularities. Rain penetration of an exterior wall system as a result of gravity alone seldom occurs, except where inadequate closures are provided at the top of the wall or at other horizontal or wash surfaces within the wall.
- **PRESSURE DIFFERENTIAL:** There is insufficient thought given to the actual outside pressure or inside pressure acting on an exterior building wall. There is real concern, however, for the difference between these two pressures, which creates a pressure differential through the wall. A substantial pressure drop through a wall is produced by high wind pressure on the face of the building in conjunction with a low internal building pressure, be it natural or artificially caused by mechanical systems. Air supply by mechanical ventilation increases internal air pressure while exhaust fans reduce internal air pressure. This pressure difference varies appreciably on the windward or leeward side of the building (horizontally) as well as low or high up on the building due to a stack effect (vertically). A windward facade experiences pressure and a leeward facade encounters suction. A positive internal pressure occurs in the upper stories with a negative pressure in the lower stories. (See drawing titled "Results of Air Pressures on Building Envelopes," Page II. 6.) A pressure differential is the primary cause of wall leakage. If this pressure differential is adequately controlled, water penetration will be virtually eliminated. Such control, as will be explained later, can be accomplished practically and economically.

At openings with high rates of air infiltration caused by an air-pressure drop through the wall, water can be dragged along the walls of the opening, which may result in rain penetration. A more serious leakage condition occurs when large quantities of surface water bridge openings up to 3/8 inches with a film of water. In this case, water is readily forced through the passage by even a small difference in air pressure through the wall.

In summary, walls leak primarily when a pressure differential develops across the wall between the outside and the inside, with water being pushed or sucked in through existing openings. This commonly occurs at the juncture or interface between different components such as units and mortar, rather than through pathways within them. Extensive experimentation shows that most leakage occurs at vertical joints rather than horizontal joints.

It is possible to provide positive pressure on the inside of the building by mechanical methods (air-handling/HVAC systems) which would keep water out. This, however, could result in extensive air leakage/exfiltration, doors that don't close and even windows being blown out. The risk of electric power failures during severe storms, as well as overnight or weekend shutdown for energy conservation should be considered in the event that this method is intended as the primary, long-term means to prevent penetration of wind-driven rain. A better way, known as the "rain screen principle", is a proven approach to eliminating water leakage.

Design utilizing the rain screen principle prescribes a rain screen wall to eliminate the pressure differential across any openings in the exterior wythe. This can best be accomplished by providing an exterior vented air space within the wall, in which the air pressure will be nearly as high, at all points and at all times, as the outdoor air pressure. The result is pressure equalization on both sides of the exterior facing, or rain screen, thus eliminating the force which otherwise causes air and water flow through openings in the facade.

### C. WALL TYPES

The evolution of exterior walls has not developed in a systematic, rational way. Rather, most design has evolved by slow, but proven, trial-by-use methods. Improved designs are needed to keep up with changes affecting exterior walls, such as increased humidification of building interiors in the winter to improve human comfort levels.

It is necessary to control the entry of water into the exterior wall so that it will not accumulate in harmful quantities. Recognizing and understanding how all of the potential exterior wall systems resist penetration of wind-driven rain is of utmost importance. Following are the three basic wall types:

- **RAIN SCREEN WALL:** A wall system that incorporates approximately equal pressure between the outside environment and a cavity within the wall system to prevent water entry.
- **DRAINAGE WALL:** A wall system having an internal cavity with or without parging or damp-proofing, where any water penetrating the exterior wall surface is collected by a pre-planned flashing system and discharged to the exterior by means of weep holes or similar openings.
- **BARRIER WALL:** A wall system of single or multi-wythe construction in which water is either prevented from penetrating the outer surface or from migrating to the inner surface of the wall. There are two kinds of barrier walls. A "mass wall" is a wall system that has either sufficient thickness (historic) or one or more collar joints solidly filled with grout or mortar (modern) to hinder the passage of water to the inside surface. A "skin wall" is a wall system which depends upon a seal at the exterior surface to prevent water from penetrating into the wall.

**RAIN SCREEN WALL:** If the area of intentional "openings" in the facing wythe is theoretically at least three times greater than the area of unintentional "openings" in the back-up wythe, then the air pressure in the wall cavity is essentially the same as the air pressure on the outside of the wall. In a practical sense, however, this ratio should preferably be ten-to-one. This provides a safety factor that ensures the air pressure, both outside and inside the wetted wall, are near equal; thus eliminating any air pressure differential which could move the water inward. The intentional "openings" placed in the exterior facing wythe should be of a predetermined amount and size with a 3/8 inch minimum least dimension to avoid water bridging over the openings during heavy rainstorms. Also, the air cavity should be sufficiently compartmentalized by being blocked off at suitable horizontal and vertical intervals, to avoid wind tunnel and stack effects. Shelf angles properly flashed at each floor level suitably close off the cavity from vertical air movement.

Vertical barriers created at corners and at a frequent spacing between corners will satisfactorily close off the cavity from horizontal air movement. Some researchers suggest a horizontal spacing for the intermittent closures as frequent as the typical column spacing. Introduction of properly sealed, continuous sheet metal or fabric (such as EPDM) at corners and vertical movement joints has worked well as an air-shutoff. Additional closures should be provided around openings in the wall.

Rain screen walls are generally the most effective means of preventing water penetration. Other advantages of this wall type include more rapid drying of the exterior wythe, good positioning of insulation (in the cavity affixed to the back-up wythe) and a minimized risk of efflorescence. Reducing the pressure differential or suction through the facing wythe substantially reduces the potential for freeze-thaw deterioration. Dependence on the back-up wythe as the primary air seal, properly located on the warm side of the wall insulation, substantially reduces the potential for air leakage and related condensation problems, especially in buildings humidified in the winter. In the event that the air cavity in the wall system is not adequately vented to the outside, attempts must be made to provide better ventilation or the wall system becomes a drainage wall. For this reason and more importantly for good, basic design, proper flashings at appropriate locations should still be utilized in a rain screen wall.

**DRAINAGE WALL:** A secondary line of defense is utilized in this type of wall which anticipates possible leakage and provides means of directing and turning out any water so that it will not reach the interior of the building. If an air cavity is maintained within the wall system, along with proper through-wall flashing and weep holes, water is diverted back to the outside. Parging or dampproofing, if used, is typically a mortar system or a bituminous material and is generally applied to the cavity face of the back-up wythe. Where insulation is employed, it should be fastened to the cavity face of the back-up wythe.

Proper flashings are mandatory in a drainage wall at all horizontal obstructions in order to divert water back to the outside. Also, the cavity must be kept relatively free of intruded mortar, mortar droppings and other debris in order to properly perform its function.

**MASS TYPE BARRIER WALL:** Very thick walls like a maze, or multi-wythe construction with filled collar joints and resulting solidity, hinders water from penetrating to the inside face of the exterior wall.

**SKIN TYPE BARRIER WALL:** A total and complete sealing of the exterior surface is intended to prevent water from penetrating into or through the exterior wall system.

Skin walls are frequently selected by designers but their intended performance is seldom obtained, or at best obtained by builders only on a short-term basis. In other words, such a wall, typically, does not work to prevent water penetration! When the seal is located where it is required to prevent both rain and air leakage, it must be almost perfect. This is difficult to achieve consistently, and if obtained, even more difficult to maintain for a reasonable time. Cleaning materials or methods employed; aging; and the extremes of the elements, including ultraviolet radiation; all play an important part in affecting the masonry unit-mortar interface and the exterior seal. Movement, from innumerable causes, constantly flex and stress joints, eventually leading to cracks and creation of openings or unintentional leakage paths through which water can penetrate. Although "skin walls" are theoretically possible, it is unreasonable to expect perfect sealing of a facade, since there are no currently known practical means for providing or maintaining a durable, completely impervious outer skin over the whole surface of the exterior wall.

## D. CONCLUSIONS

Through better understanding of the mechanisms of rain penetration, wall types and applicable masonry details, it is possible to design and build exterior masonry walls with more reliable prevention of water leakage. Use a rain screen wall. Less maintenance will thus be required, and problems which continue to worsen with age and require consistent expedient solutions can be avoided.

There are many causes and exposures, in addition to those previously mentioned, that can result in water penetration into a building. Numerous weather control problems are encountered at parapets, soffits, corner details, and grade connections to name a few. Lack of gutters or other drains, installation of window assemblies, and through-the-wall penetrations such as vents, louvers, lights, signs, etc. are just some of the items that require special design considerations.

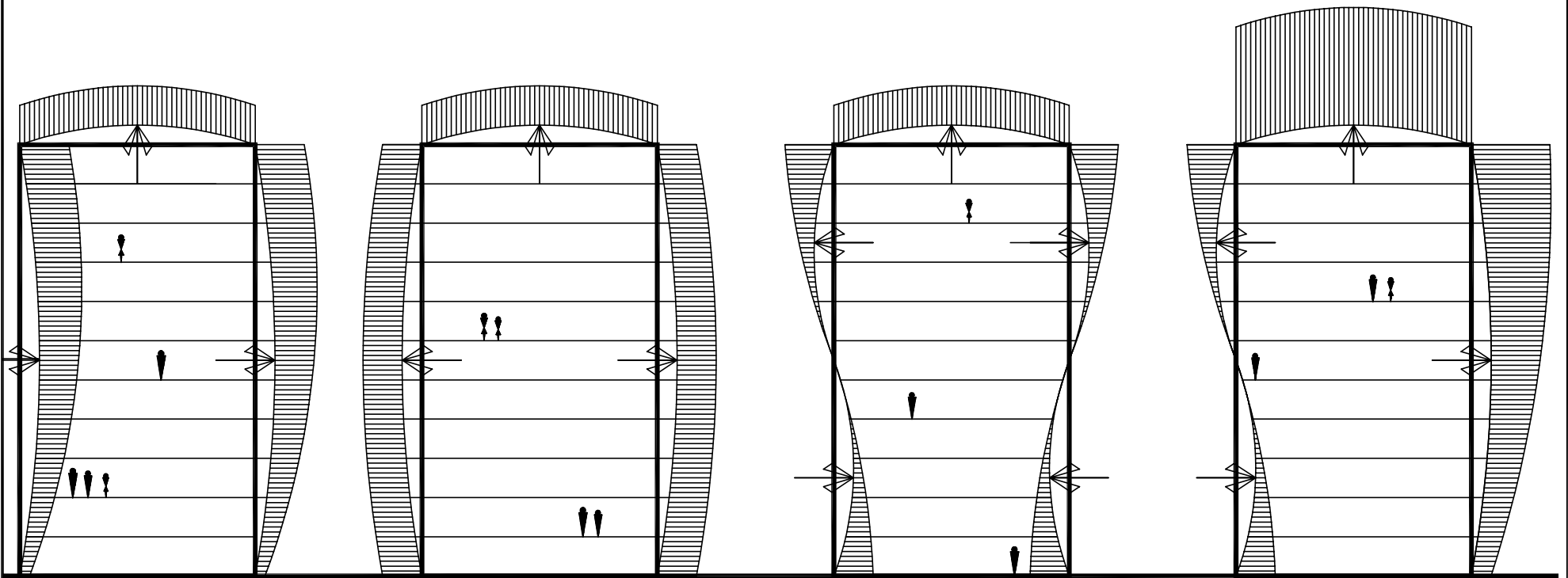

WIND EFFECT

FAN PRESSURE

STACK EFFECT

COMBINED EFFECT

RESULTS OF AIR PRESSURES ON BUILDING ENVELOPES

# GUIDELINES FOR MOVEMENT JOINTS IN EXTERIOR WALLS OF NEW BUILDINGS

## A. SUMMARY

<b>Vertical Movement Joints</b>					
Item	Type	Size	Location		
			Corners	Typ. Spacing	Special
Exterior Stone Masonry	free of non resilient materials	1/4"	at corner, or within 4' one side & 8' - 12' other side	20' - 25'	stress raisers
Exterior Clay Masonry	"	1/2"	"	20' - 25'	"
Exterior Concrete Masonry	bond broken	3/8"	"	8' - 12'	"
CMU Back-up and Partitions	"	3/8"	"	20' - 25'	"

**Notes:**

1. Cut continuous horizontal joint reinforcement in movement joints.
2. Provide joints in shelf angles at movement joints in the exterior facing wythe.
3. Provide movement joints in concrete masonry back-up halfway between movement joints in clay masonry face.
4. Increase size of number of movement joints in parapets by 50 percent.

<b>Horizontal Movement Joints</b>					
Item	Type	Size	Location		
			Foundation	Intermediate Floor	Parapet
Clay Masonry	free of non resilient materials	1/4" min. void	bond broken	void space & continuous structural support	bond broken & continuous support for all wythes
Stone & Concrete Masonry	free of non resilient materials	1/8" min. void	bond broken	void space & continuous structural support	bond broken & continuous support for all wythes

## B. MOVEMENT

Natural phenomena always causes some movement of building materials. Thus, this unavoidable movement should be anticipated and the potential magnitude likely to arise in any given situation determined with reasonable accuracy. Provision should then be made to deal with that movement by allowing for it in the design and construction. This is commonly accomplished by accommodation, or in a few rare instances by restraint. In reality, most potential movement is partially restrained with the remainder accommodated. This combination may not be all bad and, in fact, may be desirable. The masonry at the base of the wall, by virtue of weight from above and friction below, receives more restraint than the masonry at the top of the wall. The parapet typically receives the least restraint of all the masonry in the exterior wall system. If movement is not planned for in the design and if sufficient clearances are not provided for during construction, nature will prevail and cause cracking or similar distress of masonry. This could contribute to gradual deterioration by allowing moisture to penetrate into the system. Differential movement between different elements remains the primary concern.



Certain causes of building movement should be anticipated. These include temperature difference, moisture variation, chemical action and aging, and static and dynamic loading. Such loading may result in elastic and/or plastic deformation. A less common cause of movement, as an example, is freezing and thawing of typical building materials containing moisture. This action has recently been acknowledged as sometimes being significant.

Consider a commonly encountered building utilizing a concrete frame in conjunction with a clay brick exterior facing, and a in-fill concrete masonry back-up wythe that is confined between the columns and beams. All concrete products shrink in long-term service and concrete under load continues to deform with time, although at a diminishing rate. During construction of a high-rise normal-weight concrete frame building, elastic shortening of columns can be expected to be approximately 1/8 inch per typical (10 feet ±) floor height. Added to this must be the remaining long-term shrinkage and creep or plastic flow. For columns, this long-term plastic deformation will generally be less than the elastic deformation, but for flexural members, like cantilevers or spandrel beams, the long-term plastic deformation will be twice as much or more than the elastic deformation.

Concrete masonry units are at their greatest volume just after they are manufactured. They undergo shrinkage in the short term as they dry out and more shrinkage in the long term as carbonation occurs. The irreversible portion of this shrinkage for normal-weight concrete masonry units is equivalent to the unrestrained movement caused by a thermal change of approximately 100F. This is typically about 5/8 inch per 100 feet. Light-weight concrete masonry units tend to have somewhat greater shrinkage.

Conversely, all fired clay products are at their least volume just after they are manufactured and grow in long-term service. Upon completion of brick firing, stresses are retained within the units. These internal stresses are relieved by physical absorption of vaporous moisture accompanied with irreversible moisture expansion. Typical long-term expansion of such products follows an exponential curve, with the greatest expansion occurring immediately after firing. The ultimate expansion is equivalent to the unrestrained movement caused by a thermal change of approximately 200F. This calculates to about 1 inch per 100 feet.

Virtually all building materials expand and contract when exposed to daily as well as seasonal temperature changes. Mild steel as an example has an unrestrained movement of 3/4 inches per 100 feet caused by a thermal change of 100F. The magnitude of potential thermal movement depends upon factors such as air temperature, prevailing wind and orientation to the sun. The two most important predictors of thermal movement in exterior masonry are the system's thermal conductance and color. In the Upper Great Lakes region, a masonry surface temperature of -40F in the winter and 120 to 160F in the summer (lower for lighter and higher for darker) is not uncommon. Walls exposed to the elements on both sides and top, such as parapets, usually experience greater thermal movement.

Cyclic movements may not allow return of the masonry system to its original position. This ratchet effect commonly occurs, for example, with a stepped foundation wall. The masonry supported by that foundation will always tend to move horizontally in the down slope direction. As movement occurs, minute particles fall into minute openings, such as separations or cracks, and build up. When the cause of the movement subsides, the masonry attempts to return to its original position, but is prevented from fully returning because of the particle displacement. Each additional cycle starts the process anew. Some parapets without adequate provision for movement have been displaced several inches at their corners.

A realistic assessment should be made of the magnitude of movement which is to be expected. When not properly considered and addressed, movement will result in cracking, bowing or other distress in the masonry.

A table of potential movements that common frame and exterior building materials experience, as well as a table of movement coefficients, is attached, Pages III. 10 and 11.

### C. MOVEMENT JOINTS

There is considerable variation in the definitions of terms for planned joints that accommodate movement. Throughout this guide, all such joints in masonry elements will be termed “movement” joints in an attempt to avoid any conflicts with the numerous definitions of “expansion” and “control” joints which vary within the industry and with many of the Architects and Engineers practicing today. To accommodate expansion of the wall system, movement joints in masonry must be free of nonresilient materials, while those which accommodate shrinkage or contraction must have the bond of mortar to masonry unit completely broken. All movement joints must maintain the structural integrity of the wall system used.

Use of the rain screen principle and its separated wythes of masonry will accommodate movement between the wythes of masonry comprising the exterior wall system. Movement joints for both horizontal and vertical movement will be needed in the exterior masonry wall system in order to help minimize potential problems. These movement joints should be formed as the wall is built. In addition, special consideration should be given to differential movement between the various components which make up the exterior wall. For example, windows that are rigidly attached to the back-up wythe may be seriously affected by excessive horizontal movement of the facing wythe. This is usually evidenced by sealant being squashed at one jamb of the masonry opening, and sealant torn at the other jamb. A sketch showing this situation is attached, titled “University Dormitory - Results of No Movement Joints,” Page III.12.

It is essential that the contract documents clearly define the scope of work and detail for all of the different movement joints needed on a project, to the extent that field interpretation of intent is not necessary. Commonly, the drawings show the location and details of the movement joints intended, while the specifications define the materials and techniques intended.

Movement joints should be of adequate size and generally be provided at frequent spacing, at weak points in the exterior wall system, and between different materials. It is highly desirable to coordinate the location of movement joints in the exterior wall system with joints in other materials. It is preferable that vertical cold or construction joints in the foundation wall line up with the vertical movement joints in the exterior face brick wythe. It is generally mandatory that continuous shelf angles be interrupted at all vertical movement joints in the exterior face brick wythe. Details are necessary to assure accomplishment of these items.

### D. VERTICAL MOVEMENT JOINTS

To accommodate horizontal movement in any wythe of exterior masonry, there is a need for vertical movement joints. These should be located intermittently within the wall system, near or at corners, projections, or recesses, changes in wall height and at junctures with other construction. Vertical movement joints should also be located at other vulnerable locations prone to localized stress and/or cracking. Included in the latter category are changes in structure, loading and environment as well as certain other special conditions. Examples of changes in structure are changes in the framing system, wall height, thickness or mass. Large openings are also included in this category. Variation in loading can be as simple as snow load or as complicated as change from load-bearing to non load-bearing walls. Examples of changes in environment are heated/cooled to unheated/uncooled parts of facilities. Changes from typical exterior wall to wing wall horizontally or parapet vertically are part of this category. Vestibule and freezer/cooler walls are also included. Special conditions include such items as changes in material.

Typical vertical movement joints in clay products masonry should be constructed 1/2 inch in width, made free of mortar and all other nonresilient materials within 24 hours after initial construction and maintained in a debris free condition. This is to provide operable working movement joints which will be of approximately mortar joint size (3/8 inch) when later caulked in warm weather near the end of the job. Such design and construction practice will maximize the life of the liquid polymer sealant utilized, by reducing the stress levels to which the sealant is subjected. The filler material for backing of the sealant in the movement joints should be a highly-resilient, closed-cell material. In some situations, movement joints are constructed with a truly compressible material completely filling the joints. This is to prevent loose mortar from entering the movement joints during construction. Although utilizing a compressible filler is plausible, requiring the cleaning out of all movement joints instead, before the caulker is allowed onto the construction site, is the preferred method of achieving functioning movement joints.

Typical vertical movement joints in concrete products or stone masonry should be mortar joint size (3/8 inch) when constructed. Horizontal joint reinforcing (continuous ties) should be made discontinuous (cut) in the wythe where the vertical movement joint occurs. Flashing may be run continuous, or cut with end dams provided at the ends of both flashing pieces at a vertical movement joint. All such information should generally be provided in drawing details supplemented by the specifications.

Consideration should also be given in the design of the exterior facade to the difficulty of recaulking movement joints in the future. For example, joints that occur at deep recesses should be avoided. Use of any special, or fancy, expensive waterstops in the construction of the movement joints is also discouraged.

Typical spacing of vertical movement joints in an exterior facing wythe composed of clay products should be approximately 20 to 25 feet on center, with those in an exterior facing wythe composed of concrete masonry products 8 to 12 feet on center. These limitations are intended to prevent distress and subsequent cracking and allow the movement joints to properly function long term without sealant failure caused by excessive movement. This applies whether the construction is a building wall or an exterior wall of a planter or similar element. Accent bands are not exceptions. The locations of all such vertical movement joints in the exterior facing wythe should typically be shown on the elevation drawings.

For frame construction with a clay products facing wythe outside of the frame and a concrete products back-up wythe confined within the frame, it is generally prudent to provide vertical movement joints in the concrete masonry back-up wythe at the juncture with the columns and to provide vertical movement joints in the clay masonry facing wythe in the center of the spans between columns. For load-bearing construction with a clay products non load-bearing facing wythe and a concrete products load-bearing back-up wythe, the typical vertical movement joints in the concrete masonry wythe should be located approximately half way between the typical vertical movement joints in the clay face brick wythe. This is the location, along with localized stress areas, where maximum tension occurs in the concrete masonry wythe. A sketch of this condition is attached, titled "Spacing of Vertical Movement Joints," Page III. 13. Details for vertical movement joints in masonry are also attached, titled "Vertical Movement Joint Detail," Page III. 14.

Vertical movement joints in concrete masonry elements should typically extend through bond beams, except where special structural requirements dictate otherwise. All vertical movement joints in a concrete masonry wythe should be capable of transferring lateral forces along the wythe. Details of this should be provided on the drawings. Because the concrete masonry back-up wythe is protected from wetting and drying and any substantial thermal changes once a building is occupied, a 20 to 25 foot spacing of vertical movement joints is still sufficiently close to minimize cracking in that wythe. This assumes a dry, aged concrete masonry unit is being used. The staggered locations of the vertical movement joints in the facing and back-up wythes

thus eliminates the otherwise common, directly through the wall, vertical movement joint which is generally undesirable. A detail is desirable with the actual location of the vertical movement joints in the masonry back-up wythe indicated on the floor plans of the building.

As movement occurs in the exterior masonry wythe, considerable stress is developed at the building corners as the outside corners are subjected to displacement. This results in rotation or a slight change in the angle of the rather rigid masonry corner. A sketch of this situation is attached, titled "Cause of Cracking at Corners," Page III. 15. For this reason, a vertical movement joint should be provided either at the corner (no more than the thickness of the masonry wythe away) or within approximately 4 feet from the corner on the side where the greatest movement is expected to occur and 8 to 12 feet from the corner on the other side. Without such protection, corner cracking is common. Consider movement joints directly at oblique corners or immediately adjacent thereto rather than requiring special masonry units to be used. Note that vertical movement joints located at corners do not typically work in parapets.

Similarly when movement occurs, stress develops at inside corners, offsets and setbacks, which dictate a vertical movement joint coincident with the reentrant corner, at the exterior corner, or the thickness of the masonry wythe away from either corner. A strategically located movement joint is also necessary to alleviate the development of stress at changes in height, thickness or mass.

Openings are another cause of increased stress in masonry. The greater the number of openings in a given wall area, the larger the potential for stress development. With continuous horizontal relief at each floor level, such as at the heads of windows, the placement of vertical movement joints to coincide with periodic window jambs and at the outside jambs of windows at the corners performs very satisfactorily. With horizontal strip windows it is mandatory that vertical movement joints be provided at the ends of the window runs. The same applies to vertical strip windows which do not run the full height of the building.

Large openings, such as for overhead doors and entrance expanses, should have the masonry protected with vertical movement joints located at the end of the lintels providing support for the masonry above the openings. Where practical, a horizontal structural element secured to the structural frame should be designed and used in lieu of a loose lintel. Entry canopies, loading docks and similar areas also require close scrutiny for the location and placement of vertical movement joints in order to minimize stress and prevent cracking of the masonry. An opening of 8 feet or more should have movement joints provided at or very near both sides of the opening.

Masonry openings for doors or similar apertures that occur in multiple building elements (such as partially in the foundation wall and partially in the typical exterior masonry wall system above) are discouraged unless handled very delicately in regard to adjacent movement joints needed. Too frequently the doors and their frames become racked.

With frame construction, vertical movement joints in the concrete masonry back-up wythe at the juncture with the columns are appropriate. Typical non-load-bearing masonry should not be designed to provide lateral support for a structural steel frame. Any masonry rigidly connected to the structural frame will most likely crack. This commonly occurs when voids at masonry enclosing columns are slushed full of mortar. When lateral support and stability of the masonry is needed, flexible anchorage along with a clear space between the structural element and the enclosing masonry will minimize problems.

All movement must be taken into account, with special provision made for differential movement between the various components in the exterior wall. This commonly means utilization of vertical movement joints between major elements of construction or at change of materials.

Where movement is expected to increase, vertical movement joints must commensurately be increased. More movement joints will be needed where unheated buildings, walls exposed to the elements on both sides, or changes in climatic exposure occur. It is common to double the number of vertical control joints used in parapets over that used in the walls below. As another option, the same number of vertical movement joints can be used but their size increased by 50% (to 3/4 inch for clay products masonry) when constructed. Such need can be justified based on the greater temperature variation expected when coupled with less restraint imposed on the parapet. All such vertical movement joints, however, must extend completely through the parapet, through stone or concrete caps and all courses of masonry down to the roof slab or to the structural support immediately below. Both location of such vertical movement joints and details should be provided on the drawings to enforce this requirement.

#### E. HORIZONTAL MOVEMENT JOINTS

Without horizontal movement joints, loads imposed on the frame of a building may be transferred to the masonry, causing distress. In order to accommodate vertical movement in a typical exterior masonry wythe, there will be need for horizontal movement joints intermittently and at the top of the wall. Different provision will be needed at the base of the wall to accommodate horizontal movement.

If a traditional brick ledge is provided above grade and perimeter insulation is held at or below grade, only a nominal bond break between the ledge on the concrete foundation and the masonry above is needed to provide for differential movement between the two masses. This can simply be a 15# roofing felt. If an inverted shelf angle is mounted to the foundation wall for support of the exterior masonry wythe, that in itself is a sufficient bond break. If no brick ledge can be utilized or if perimeter insulation is brought right up to the level of the brick ledge, a through-wall flashing or flashing system to protect the insulation will be needed. This will also serve as the bond break. These items prevent raveling of the mortar bed as well as cracking or spalling of the foundation corners. If there is no brick ledge or if any cold joints or other imperfections exist in the construction such that water could enter, flashing is mandatory.

Usually, the wall insulation is located in the exterior wall cavity secured to the concrete masonry back-up wythe as well as the building frame. For an occupied building, this results in a thermally and moisture stable back-up system. There should be a roughened surface or a continuous notch in the top of the floor slabs, or periodic dowels placed there to help provide lateral support for the back-up wythe at its base. A detail is attached, titled "Typical Wall Section Detail," Page III. 16.

At the typical intermediate floor, a horizontal movement joint is needed to provide relief for the exterior masonry wythe and transfer whatever load it carries back into the structural frame of the building. Angles, tees or plates can be used for this purpose, should be relatively uncomplicated, but must be designed to carry all loads to be imposed upon them. They are generally located at the bottom of the perimeter spandrel beams. These structural elements are commonly used as a desirable combination of both masonry support and window head to avoid duplication of effort. The pressure relieving, void space between the structural element and the masonry below should be initially constructed with at least 1/4 inch to accommodate long-term frame and horizontal structural element deformation in conjunction with the moisture expansion of clay products. Such a dimension assumes that suitable structural design and proper details, such as full height shims behind the upstanding leg of the horizontal structural element, will be provided. Lack of such provision could allow rotation of the structural element, consequently negating the appropriateness of the recommended space. All mortar and rigid materials must be kept out of the joint to prevent loads being transmitted from the support to the masonry directly below. As with vertical movement joints, some horizontal movement joints are constructed with a truly

compressible material completely filling the joint in an attempt to prevent loose mortar from entering during construction. Inspection and cleaning out of all movement joints prior to application of sealant is the preferred method of achieving functioning movement joints.

Horizontal structural elements such as shelf angles should never be made truly continuous (sections welded together) around the entire perimeter of the building. Volume changes due to thermal movement, during as well as after construction, may result in distress. As previously indicated, joints in the continuous horizontal structural element (shelf angle) should coincide with all vertical movement joints in the exterior facing wythe. It is strongly suggested that all corners for the continuous horizontal structural element be prefabricated or at least mitered in the shop and welded in the field. This is to eliminate void spaces between angles at the corners which may subsequently be filled with mortar during the construction process. If this filling occurs, the corners will act as a column of masonry resulting in cracking of the exterior facing wythe due to its overloading. The only exception for the prefabrication recommended is where vertical movement joints occur right at the corner and the joints between structural elements coincide with the movement joints in the masonry. Where the framing is interrupted, such as at stair towers, the corresponding change in height of the horizontal structural elements should be isolated by vertical movement joints. Details on the drawings should be provided for all the various conditions expected to be encountered.

The masonry units in the first course, bearing directly on the structural element, may be of conventional size and configuration. This will, however, create a larger than typical horizontal joint, but will allow the through-wall flashing with drip to come out directly beneath the masonry. This locates the sealant beneath the flashing and its drip which means the sealant does not prevent water from exiting and the sealant is also protected from ultraviolet exposure. If a normal size bed joint is desired at the horizontal movement joint, a notched brick laid with the notch pointed up in the course directly beneath the structural element can be used. This has the same benefit as the larger than usual horizontal movement joint utilizing a conventional masonry unit. A third, less desirable, option is to use a notched masonry unit pointed down in the first course bearing directly on the structural element. This causes complications in the flashing system which usually results in the sealant being placed above the flashing and the obvious need for the sealant to be interrupted frequently at the toe of the structural element to avoid trapping water in the wall system. The lack of sealant interruption is too frequently associated with entrapment of water within the exterior wall system and subsequent shelf angle rusting. A shelf angle detail and the three options mentioned are attached, Pages III. 17-20.

Where loose (unattached to the structural frame) metal lintels occur, common at door and certain window heads, mortar should be raked out at the toe of the bearing structural member in preparation for sealant in the joint in front of the lintel. The lintel should have a bearing length of at least 4 inches on the masonry with a bond break between the two elements. A hot dip galvanized treatment after fabrication will render the lintel corrosion resistant and may provide the necessary bond break. When vertical movement joints do not occur at the ends of the lintel, a slight space (compressible filler preferred) should be provided in the mortar bed joint at the ends of the lintel to minimize the pry bar effect of the lintel on the masonry as the lintel expands or contracts. All of these items occur beneath the through-wall flashing and within the confines of the flashing end dams. If vertical movement joints are desired in the immediate area, they should occur upward from the ends of the loose lintels. Vertical movement joints in the masonry below the opening generally line up with the jambs of the masonry opening.

There is a difference in mass, composition, and exposure between parapets and the masonry below. Parapets should be separated from the typical exterior wall by means of a horizontal movement joint. This becomes extremely critical when there is appreciable horizontal movement of the roof system or when the parapet bears on the non-bearing edge of a prestressed roof element. When a long-span structural roof element bears on and is buried within the

masonry, it acts like a giant pry bar. When a plate or inverted angle is provided at the top level of the roof slab, just a moderate (up to 12 inches) height parapet occurs above, and the back face of the parapet is covered with an upturned roofing membrane, through-the-wall flashing may be eliminated. If a masonry wall continues above the roof as part of a penthouse, stair tower, elevator tower or the like, flashing is necessary.

In the very special instance of a low, single-story, load-bearing masonry facility which requires a parapet, utilization of a bond break and sealant between the parapet and the exterior wall at the level of the top of the roof deck has been accomplished without excessive parapet tipping. A typical detail is attached, titled "Typical Roof Edge Detail (stone or concrete cap)," Page III. 21. Roof overhangs also require special treatment at the interface with the exterior masonry wall system to provide for differential movement. The horizontal juncture between bands of different materials or the same material but with different composition, color, texture, or size, may also require special consideration due to different movement characteristics that may be involved. In some situations, even flashing may be appropriate.

#### F. SPECIAL MOVEMENT JOINTS

While this entire discussion of movement and movement joints has, thus far, concentrated on the exterior wall system, the interior masonry may also require some consideration. Temperature and moisture variations within modern buildings are minuscule once the building is occupied, but there are wide variations during and immediately following construction causing movement that must be accommodated. Movement joints should be provided in lengthy runs and at critical locations of interior concrete masonry partitions to precrack rather than allow random cracking. Spacing of typical movement joints should be approximately 20 to 25 feet on center and preferably occur at weak points such as door jambs/ends of lintels. Intended locations should be indicated on the drawings. Except in structures with long spans or containing prestressed concrete elements, partitions usually terminate tight against the structure above. Units should be wedged tight and the top joint filled with mortar. Wherever the junctures are exposed to view, the mortar is commonly raked back and sealant is installed.

Provision should be made for some differential movement to avoid cracking of cross walls (partitions) where they juncture with the exterior wall system. Walls outside of the main exterior wall, such as at vestibules, are even more susceptible to potential cracking. A detail is attached, titled "Exterior Wall/Cross Wall Juncture Detail," Page III. 22. An alternative is to provide lateral support for the cross wall at its top and then provide a movement joint between the exterior wall and the cross wall.

If a masonry faced incinerator or chimney is associated with a project, there should be a void or air cavity between the facing and the flue or liner. This is not only for masonry durability but to accommodate the appreciable, multi-directional, differential movement that should be expected.

Head joints in horizontal surfaces, such as stone or concrete copings, should be raked, properly backed and sealed. This is in addition to true movement joints being provided 20 to 25 feet on center. The same applies to stone or concrete belt courses and panels. For stone or concrete sills at the base of a masonry opening, raking, properly backing and caulking is usually sufficient, except for large (8 feet or more) openings. Bed joints associated with any of the aforementioned conditions should not be caulked, unless special means are taken to prevent entrapment of water within the involved masonry element.

Exterior slabs on grade at the perimeter of the building exterior must be expected to move up and down as frost enters or leaves the earth below the slabs. A space must be maintained between the edge of the slab and the face of the masonry to prevent translation of the frost heave into eccentric loading or spalling of the masonry.

For mortared (rigid) paver brick and quarry tile installations, learning experience dictates that movement joints be provided at the perimeter of such construction where it butts up to other construction, at a frequent spacing in both directions (12 to 20 feet is acceptable), and at points of increased stress such as projections, notches and the like.

Spalling of concrete or masonry is too common where metal railings or similar items are cast or built into a horizontal or near horizontal surface. Differential movement is usually of lesser cause than metal corrosion although both items may play a part in the deterioration. To avoid this situation, the railings should have their own movement joints and should generally be mounted on the side of the elements to which they are to be attached, rather than penetrating a horizontal surface.

## G. CONCLUSION

Each project is somewhat unique with many variations from the typical and will thus likely require different size and/or spacing of movement joints throughout the construction. If movement is not adequately taken into account and movement joints are not planned ahead of time, nature will place them, and in most situations it seems they will be of a type and in a location where they are the least desired.

This guide is an attempt to provide some practical rules of thumb to prevent a recurrence of relatively-easily, avoidable problems related to masonry movement. As such, most of the information and ideas contained herein have been gained from experience, rather than an attempt to apply theory. Extreme, complex conditions may require unique design as well as construction procedures to stay out of trouble; both of which are difficult to achieve and probably should be avoided whenever possible.

## H. LIST OF ATTACHMENTS

- Causes and Types of Movements for Building Materials, Page III. 10.
- Coefficient of Movements of Masonry Materials, Page III. 11.
- University Dormitory - Results of No Movement Joints, Page III. 12.
- Spacing of Vertical Movement Joints, Page III. 13.
- Vertical Movement Joint Detail, Page III. 14.
- Cause of Cracking at Corners, Page III. 15.
- Typical Wall Section Detail, Page III. 16.
- Shelf Angle Details, Pages III. 17-20,
- Typical Roof Edge Detail,(Stone or Concrete Cap), Page III. 21.
- Exterior Wall/Cross Wall Juncture Detail, Page III. 22.



### Causes and Types of Movements for Building Materials

Cause	Result	Concrete	Steel	Wood	Stone	Concrete Masonry	Clay Masonry
<b>Load Application</b>	Elastic Deformation	yes	yes	yes	yes	yes	yes
<b>Sustained Load</b>	Creep Contraction	yes	yes	yes	yes	yes	yes
<b>Temperature Change</b>	Expansion/ Contraction	yes	yes	yes	yes	yes	yes
<b>Moisture Content Change</b>	Expansion/ Contract	yes	no	yes	yes	yes	yes
<b>Cement Hydration/ Carbonation</b>	Permanent Shrinkage	yes	no	no	no	yes	no
<b>Moisture Absorption</b>	Permanent Expansion	no	no	no	no	no	yes
<b>Freezing When Wet</b>	Expansion	yes	no	no	yes	yes	yes

## Coefficients of Movement of Masonry Materials

Material	Creep	Thermal Expansion	Permanent Shrinkage	Permanent Moisture Expansion	Reversible Moisture Expansion	Freezing Expansion
	$\times 10^{-7}$ in/in/psi	$\times 10^{-6}$ in/in/°F	$\times 10^{-4}$ in/in	$\times 10^{-4}$ in/in	$\times 10^{-4}$ in/in	$\times 10^{-4}$ in/in
	low design high	low design high	low design high	low design high	low design high	low design high
<b>Clay Masonry</b>	0 .7 10.0	1.7 4.0 9.0	- - -	0 3.0 10.8	.7 1.8 2.0	0.2 3.0 4.5
<b>Concrete Masonry</b>						
<b>lightweight</b>	2.7 3.0 3.3	3.1 4.3 4.6	2.0 6.0 17.0	- - -	1.5 3.0 4.8	- - -
<b>normal weight</b>	1.6 1.8 2.0	3.7 5.2 7.2	2.0 4.8 5.3	- - -	1.4 2.0 5.0	0.3 0.6 0.8

Note: The values given represent averages at the low and high end of the data.  
 Recommended design values are near the characteristic.

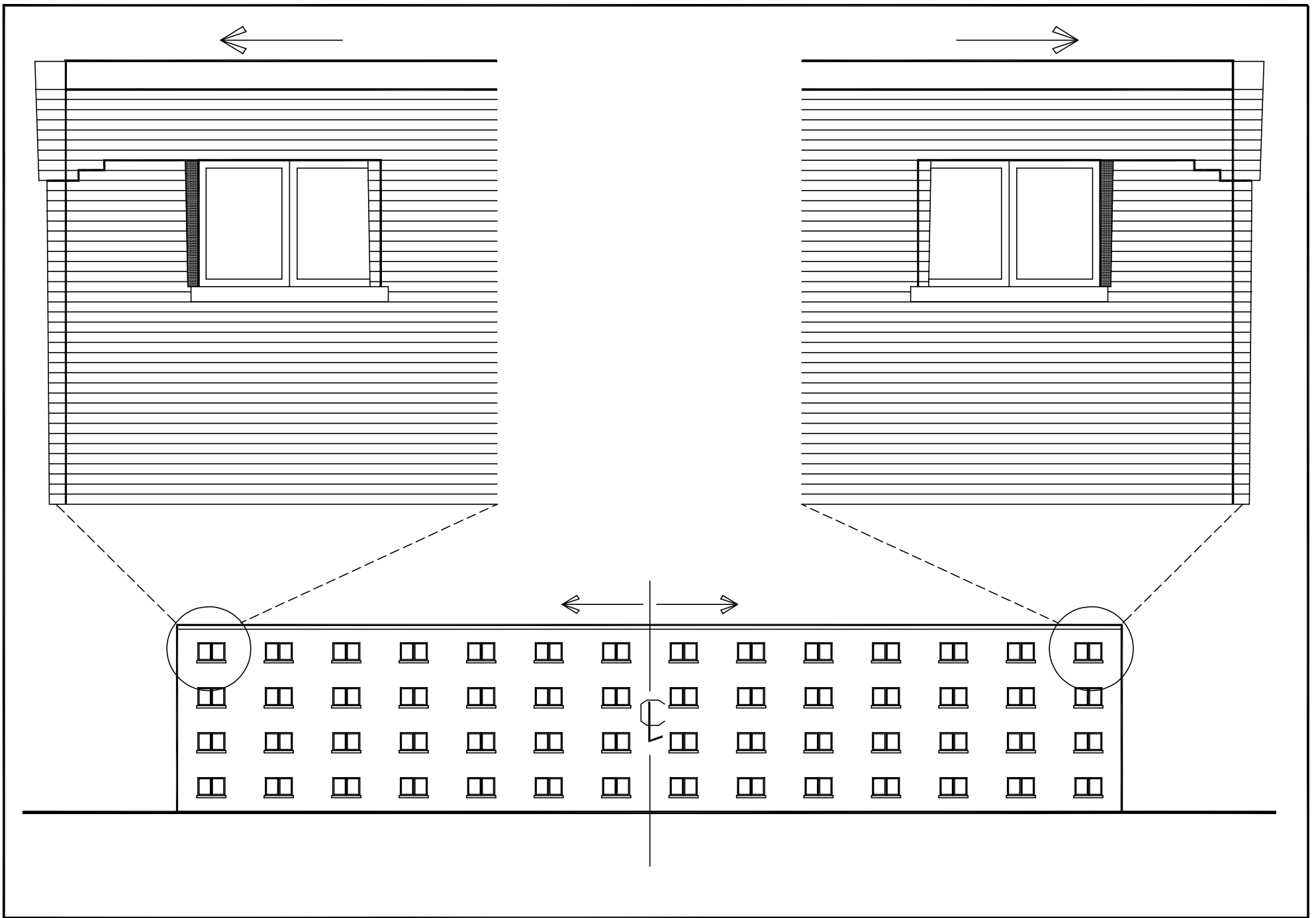

UNIVERSITY DORMITORY – RESULTS OF NO MOVEMENT JOINTS

Note: Typical spacing of vertical movement joints in an exterior facing wythe composed of clay products should be approximately 20 to 25 feet on center.

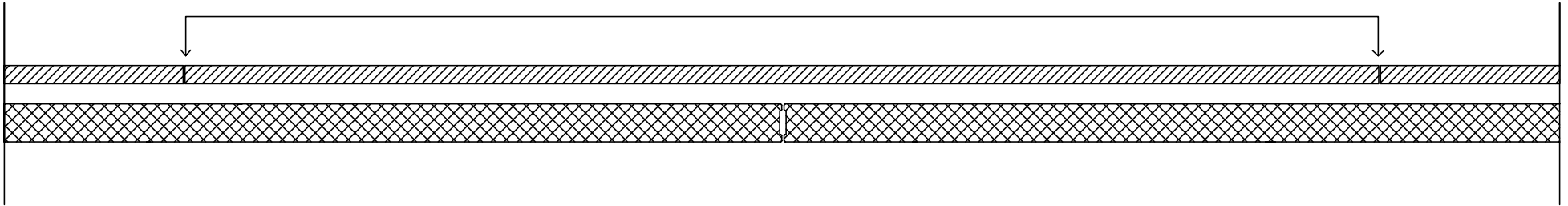

Note: Maximum compression in the brick (because of restraint) occurs halfway between the vertical movement joints in the block.  
Maximum tension in the block (because of crosswires) occurs halfway between the vertical movement joints in the brick.  
For load bearing construction with a clay product non-load bearing facing wythe and a concrete product load bearing back-up wythe, the typical vertical movement joints in the concrete masonry wythe should be located approximately halfway between the typical vertical movement joints in the clay face brick wythe.

### SPACING OF VERTICAL MOVEMENT JOINTS

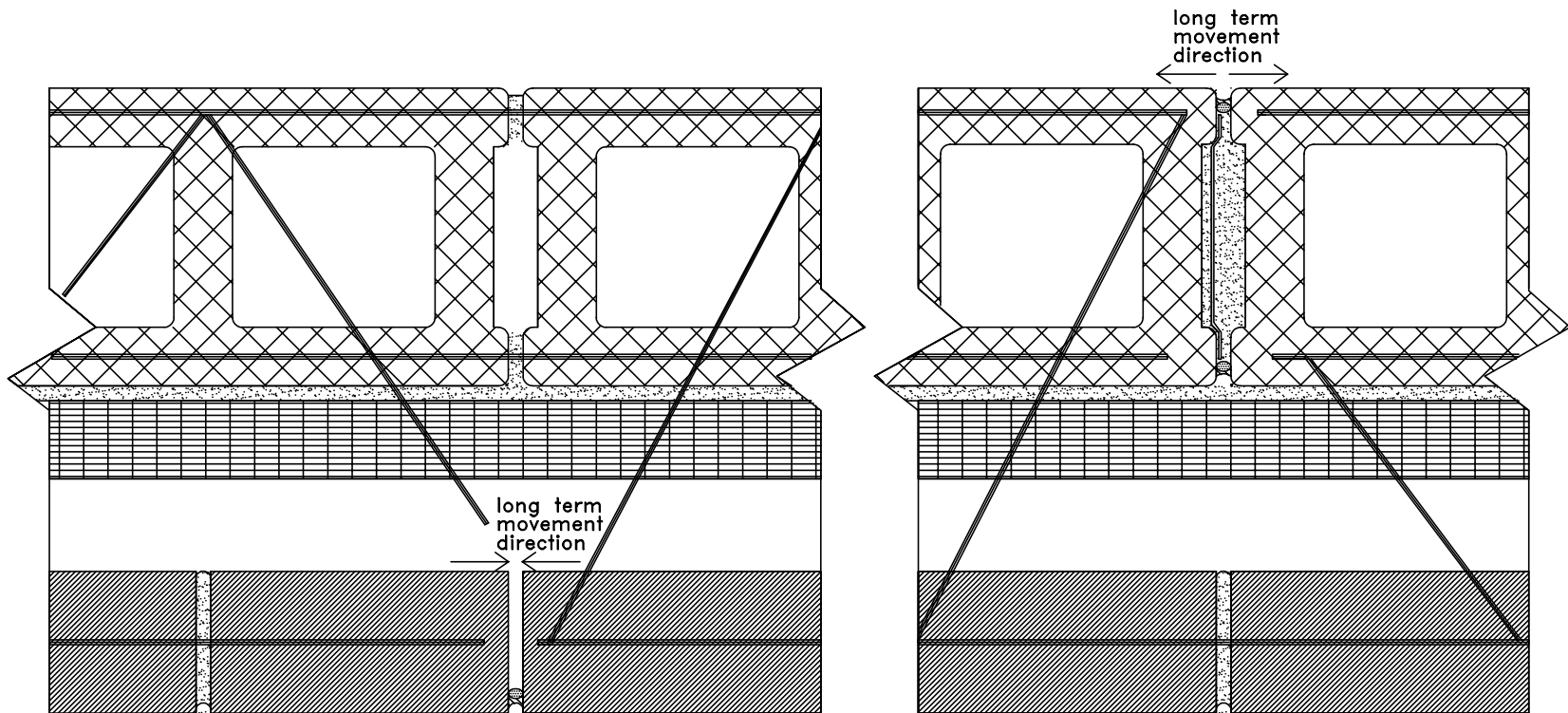

note: horizontal joint reinforcing (continuous ties) should be made discontinuous (cut) in the wythe where vertical movement joints occur.

vertical movement joints in the concrete masonry back-up do not line up with the vertical movement joints in the clay masonry facing, and occur about half-way between them.

### VERTICAL MOVEMENT JOINT DETAIL

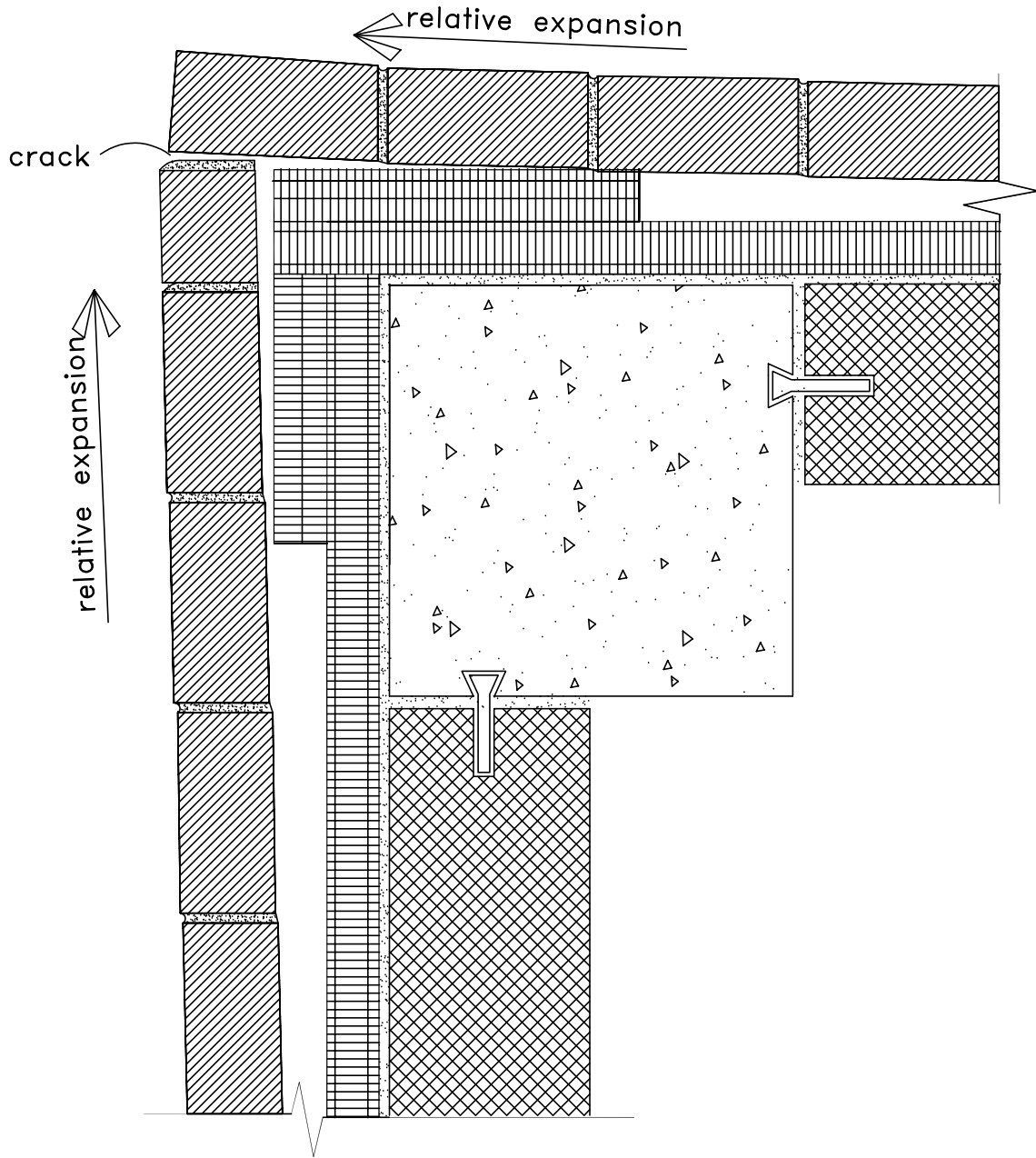

CAUSE OF CRACKING AT CORNERS

1. BRICK
2. CMU
3. CONTINUOUS WALL TIE
4. ANCHOR
5. DOVETAIL ANCHOR SLOT
6. 2" AIR CAVITY
7. 2" RIGID INSULATION
8. 3/8" PARGING
9. PLASTIC DISK WEDGE
10. SPANDREL
11. WEEP/VENT OPENING
12. VENT OPENING
13. CONTINUOUS NOTCH

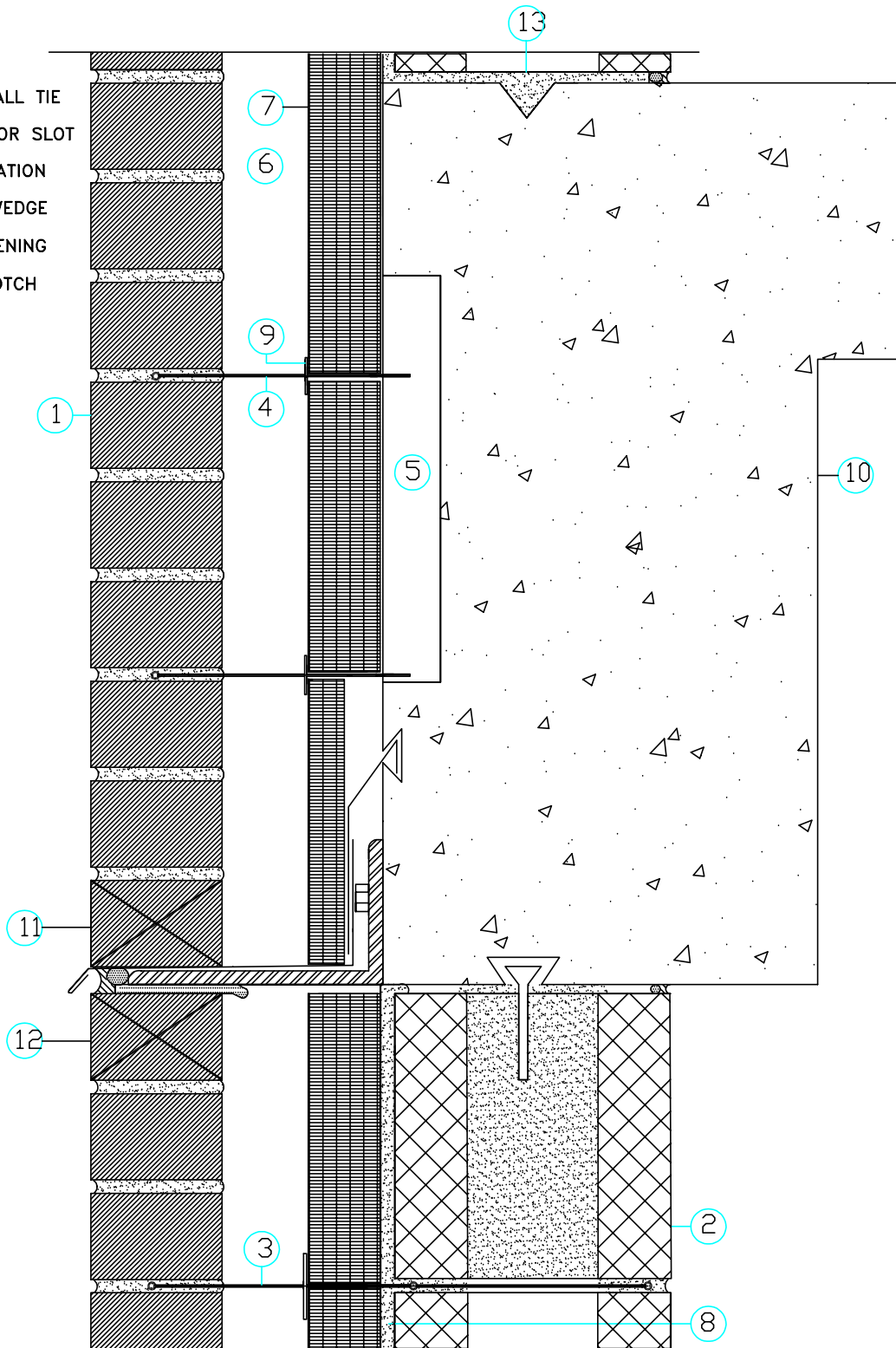

TYPICAL WALL SECTION DETAIL

1. BRICK
2. 2" RIGID INSULATION
3. 1" RIGID INSULATION
4. ANCHOR
5. PLASTIC DISK WEDGE
6. FLASHING
7. 4" x 7" x 3/8" ANGLE
8. CONTINUOUS POLYETHYLENE
9. SEALANT BACKER ROD
10. REGLET
11. DOVETAIL ANCHOR SLOT
12. WEEP/VENT OPENING
13. VENT OPENING

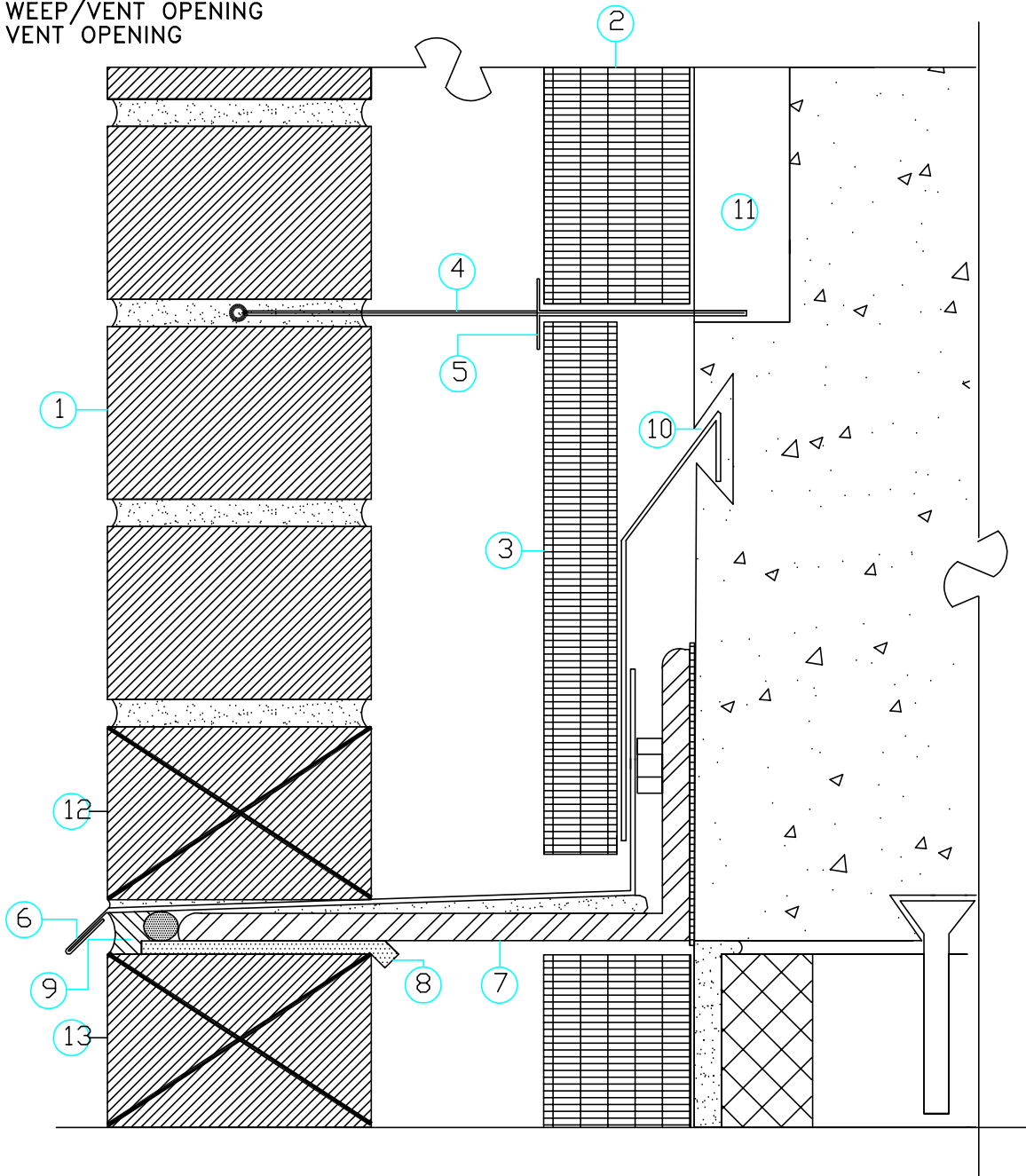

SHELF ANGLE DETAIL



1. WEEP/VENT OPENING
2. FLASHING WITH 3/4" DRIP
3. SEALANT & BACKER ROD
4. MORTAR
5. ANGLE
6. CONTINUOUS POLYETHYLENE PAD
7. VENT OPENING

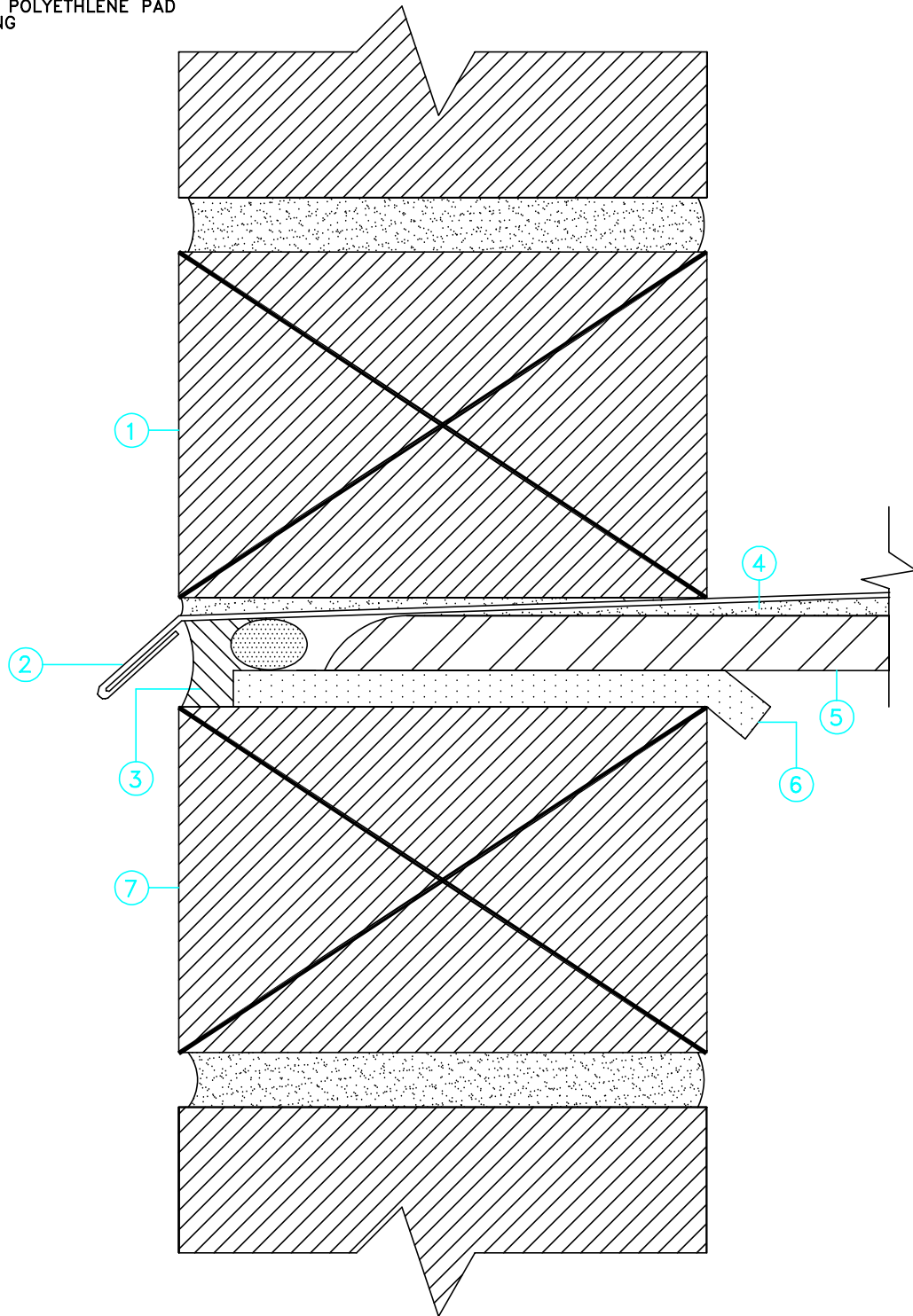

SHELF ANGLE DETAIL (OPTION A)

1. WEEP/VENT OPENING
2. FLASHING WITH 3/4" DRIP
3. SEALANT & BACKER ROD
4. MORTAR
5. ANGLE
6. CONTINUOUS POLYETHYLENE PAD
7. VENT OPENING

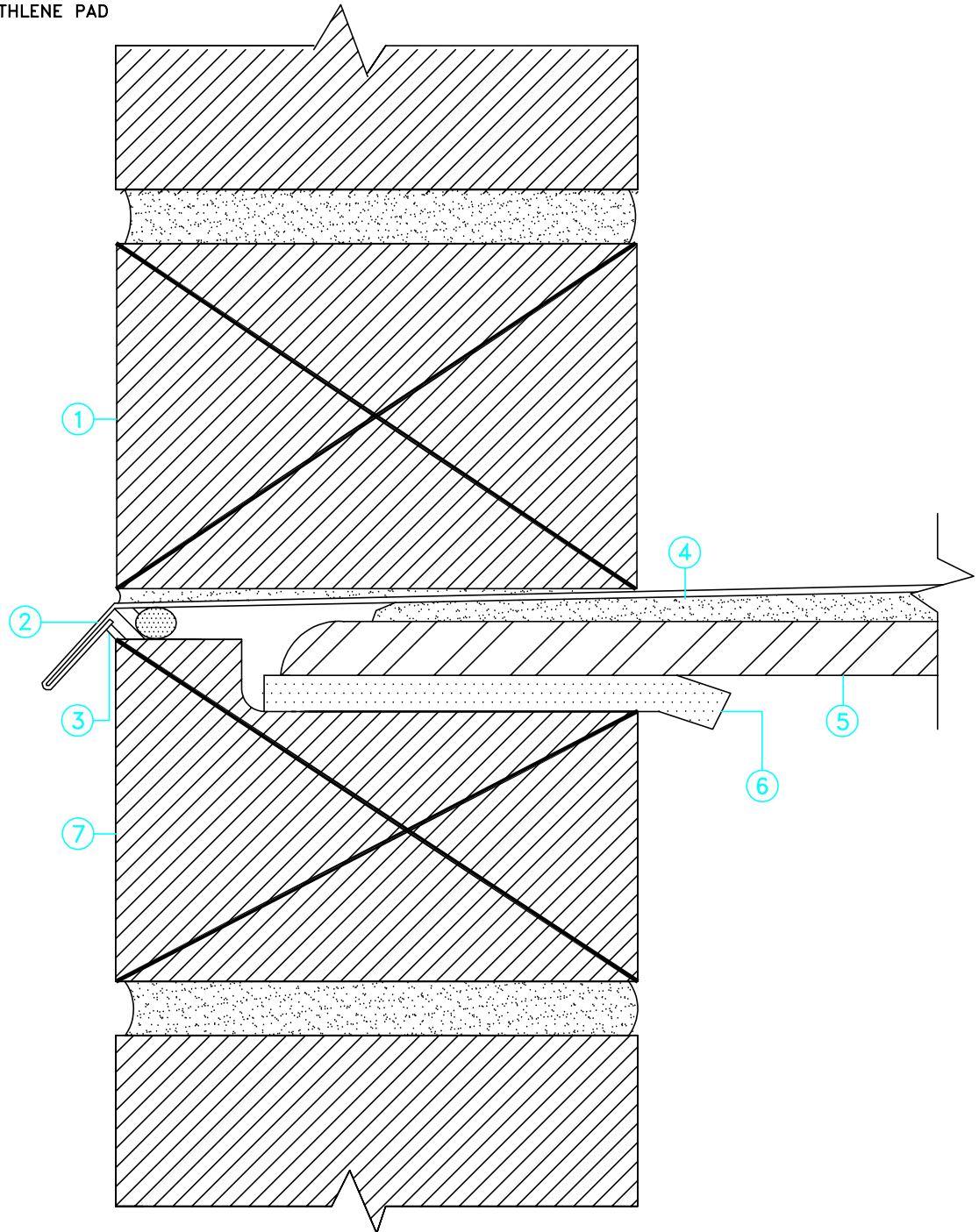

SHELF ANGLE DETAIL (OPTION B)

1. WEEP/VENT OPENING
2. FLASHING WITH 3/4" DRIP
3. SEALANT & BACKER ROD, INTERRUPTED MAX. 24" o.c.
4. MORTAR
5. ANGLE
6. CONTINUOUS POLYETHYLENE PAD
7. VENT OPENING

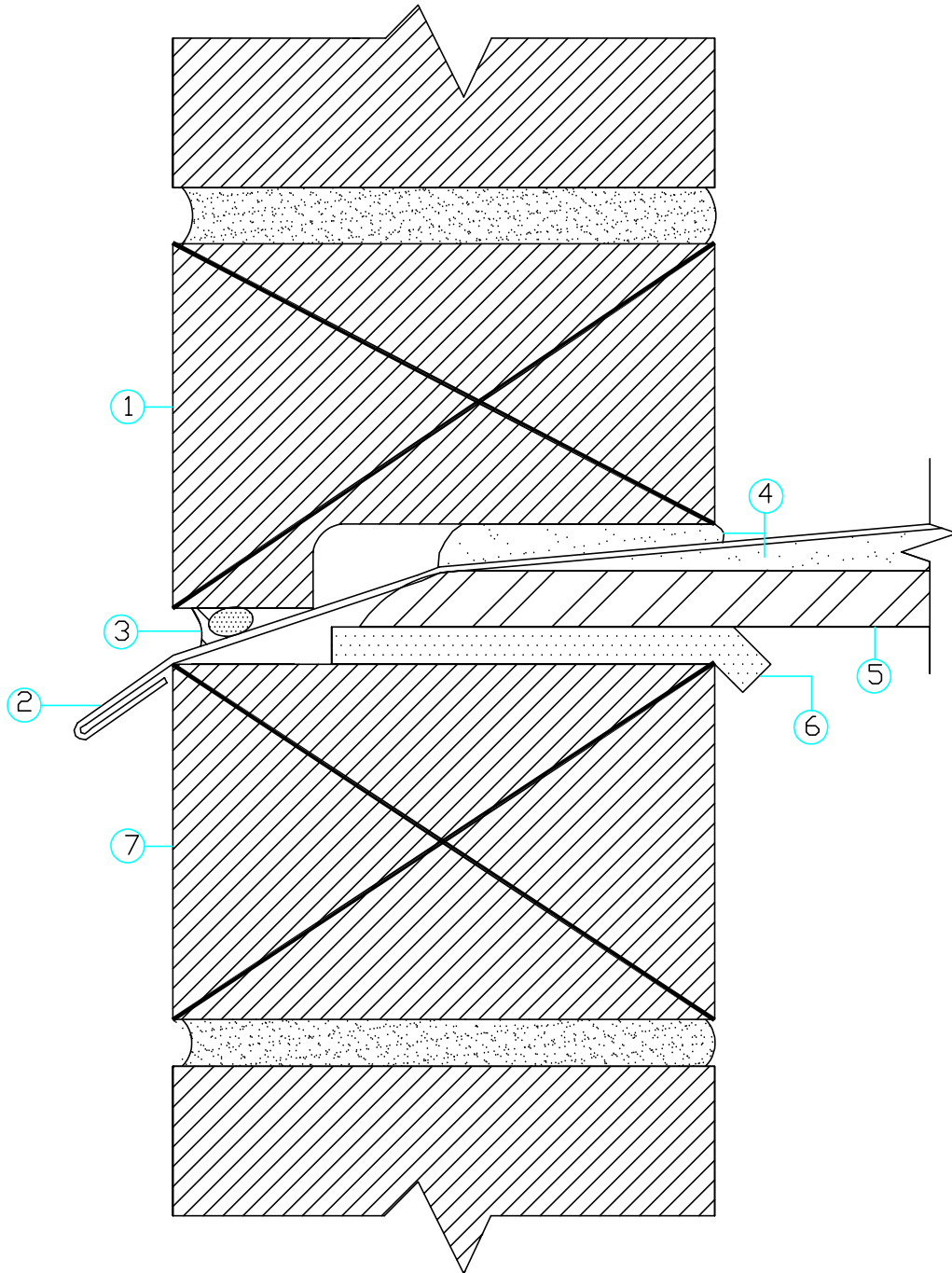

SHELF ANGLE DETAIL (OPTION C)



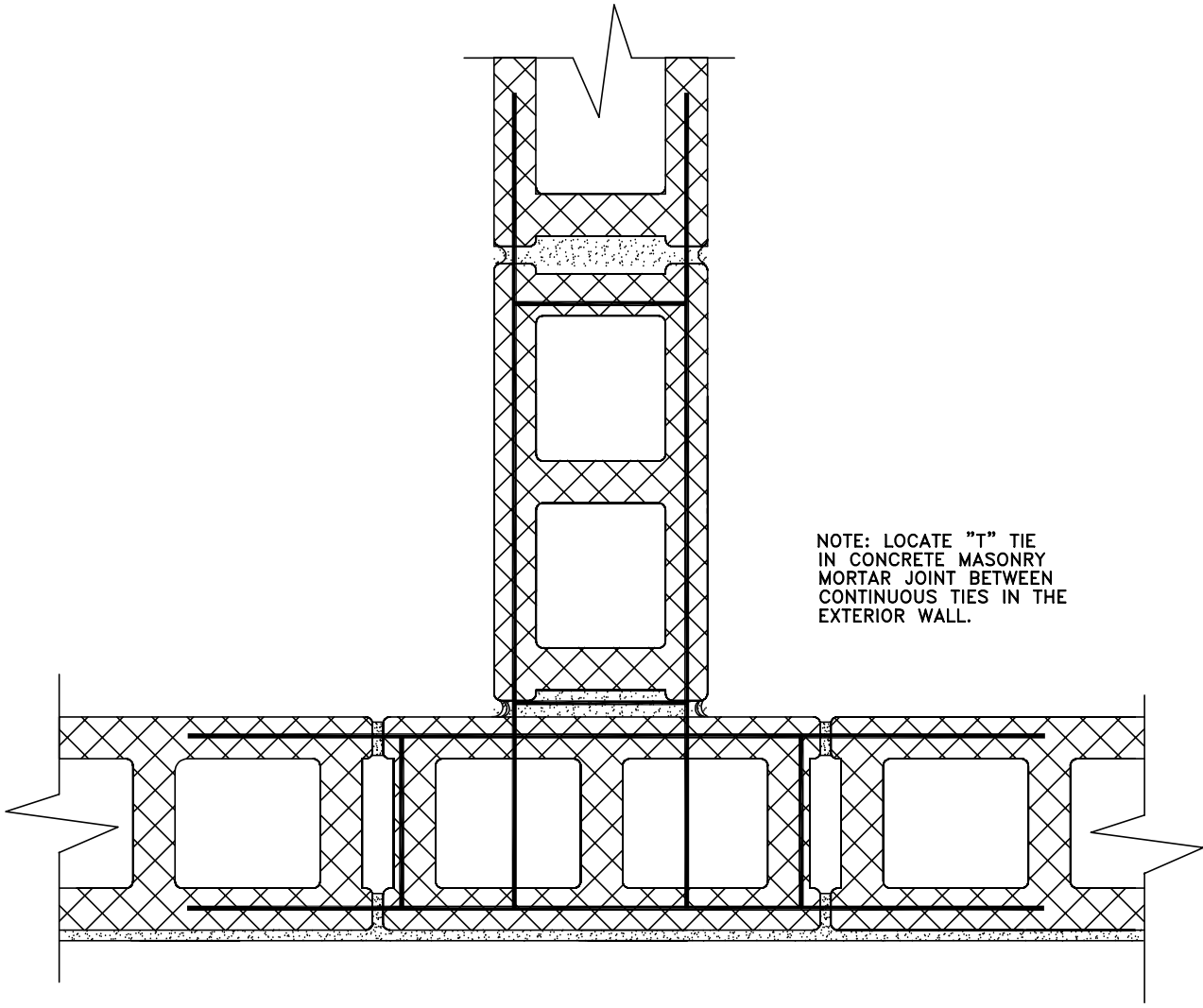
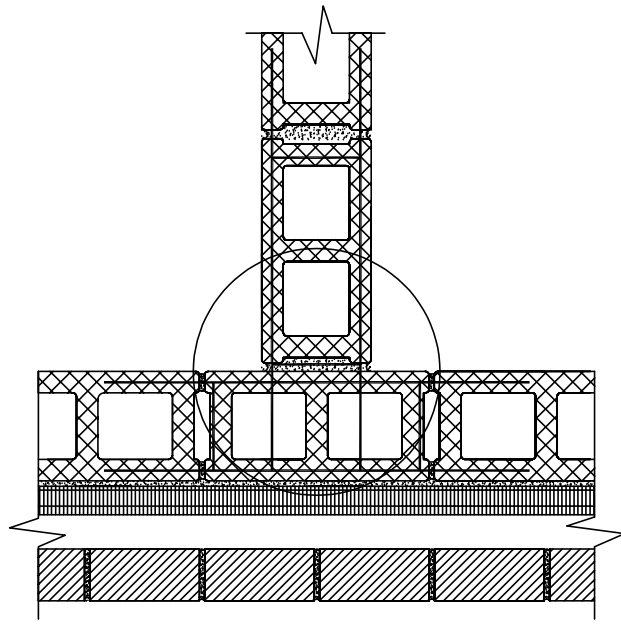

EXTERIOR WALL / CROSS WALL JUNCTURE DETAIL

## **GUIDELINES FOR EXTERIOR WALL FLASHING**

Through-wall flashings at all intermediate masonry weight supports, such as shelf angles, and at the heads and sills of all wall openings (for windows, louvers and door heads) should incorporate details as follows:

1. Corrosion-resistant stainless steel is the preferred flashing material. AISI Type 304 with 2D Finish (2B alternate) is suggested. Consider minimum 26 (24 alternate) gage thickness where counterflashing is to be attached thereto and minimum 28 (26 alternate) gage thickness elsewhere. Plain or deformed metal patterns in the sheet goods may be used. Terne (lead-tin) coated stainless steel is permissible where budget permits.
2. Metal flashing of type, thickness and size indicated should layout in plan and configure in cross-section according to the plans and specifications. Shop fabricate in accordance with the Sheet Metal and Air Conditioning Contractors National Association (SMACNA) Architectural Sheet Metal Manual, except where superseded by more stringent requirements mentioned herein. Typically, form sections in 8 or 10 foot lengths. Bend and break to true, sharp and straight lines and angles. Where flashing intercepts other elements, cope to accurate fit, sealing as required.
3. The exposed exterior edge of flashings should uniformly extend out a minimum of 3/4" with a minimum of 1/2" continuous hem and be turned downward with approximately a 45 degree bend to serve as a drip. Notch hem and taper-cut drip for the underlying piece at joints.
4. The concealed portion of flashings should be turned up to form a back dam to contain water, with the interior top edge secured in a continuous reglet or terminated in the back-up masonry wythe with a minimum face shell embedment into a mortar bed joint. (Use of a back leg, where appropriate, should be accomplished.)
5. End dams should be installed at the longitudinal ends of flashings over lintels, at column abutments, and adjacent to major building expansion joints, by turning the flashing material up into a head joint in the masonry a minimum of 1-1/2". See sketches attached titled "Flashing End Dam," Pages IV. 3-4. Fabricated corners at end dams (selvage) to be sealed to contain water by being soldered in the shop or treated with sealant in the field, as specified. Flashing need not be made discontinuous at typical movement joints.
6. Flashing at corners should be continuous around the corners. One piece, prefabricated in the shop, interior and exterior corner pieces should generally be required. See sketches attached titled "Flashing Internal/External Corners," Page IV. 2. They should be not less than 18" in length both ways from the mitered corner, with final fastening of the corner. Field measurements may be needed to ensure proper fit. Prefabricated flashing elements may have locked and soldered or riveted and soldered joints done in the shop. Mechanical field adjustment of prefabricated elements will not be tolerated.
7. Lap joints should overlap at ends for each piece a minimum of 4". All field joints and penetrations should be treated with sealant to make them watertight. (This is best accomplished by providing a continuous bead of sealant within the lap itself.) An alternate is to provide end dams, back to back, at joints between flashing pieces.
8. Flashing should be located at the same horizontal joint as the weight support of the masonry (not in other joints above or below), with only one weakened plane of bond created.

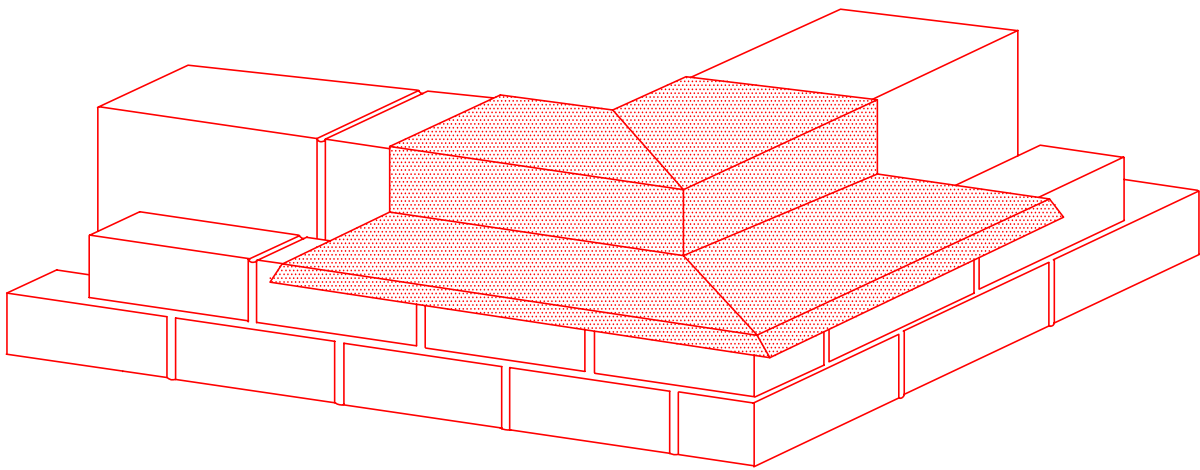
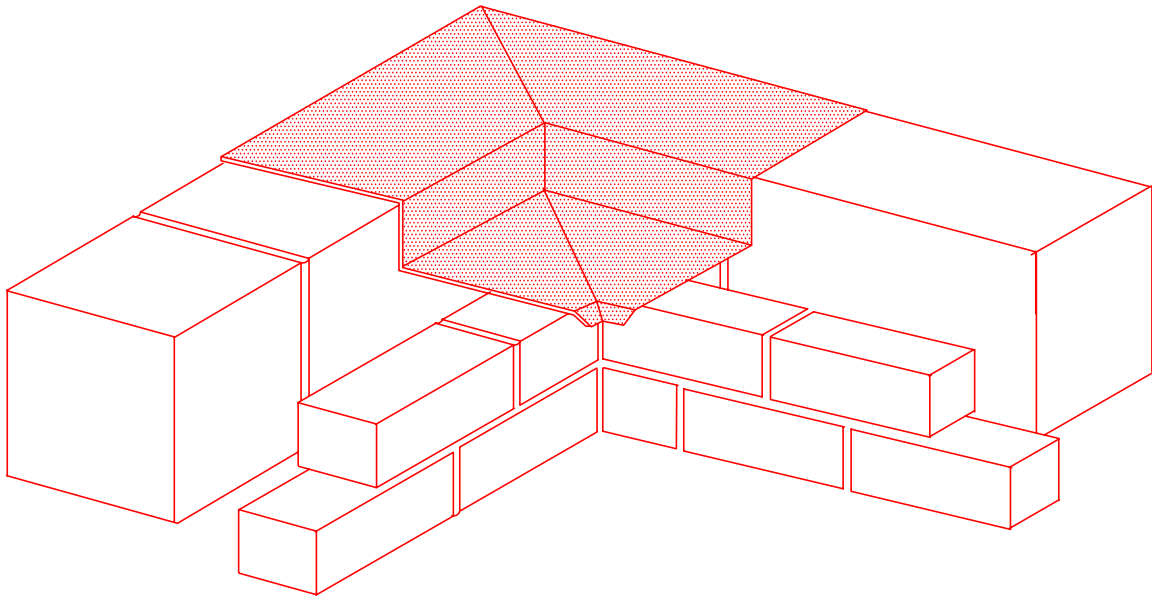

FLASHING INTERNAL/EXTERNAL CORNERS

REFER TO PAGE IV.4

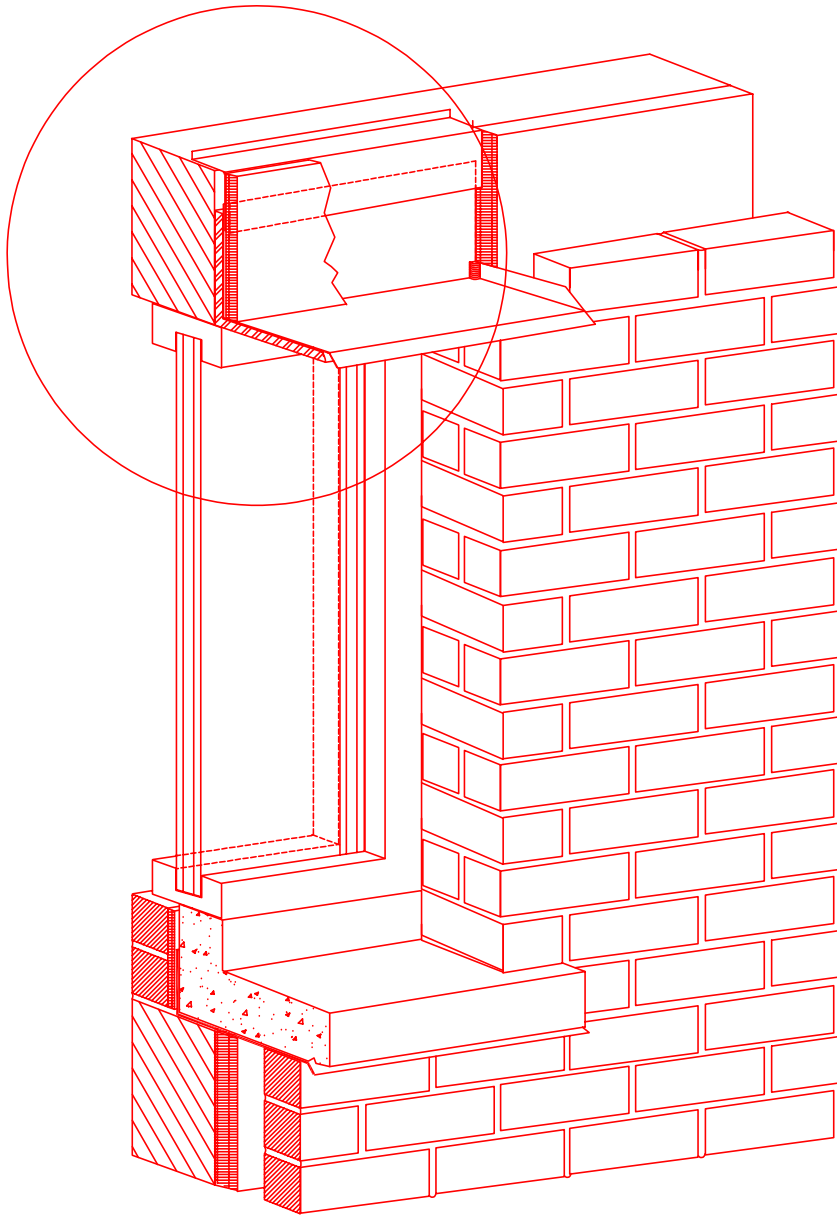

FLASHING END DAM



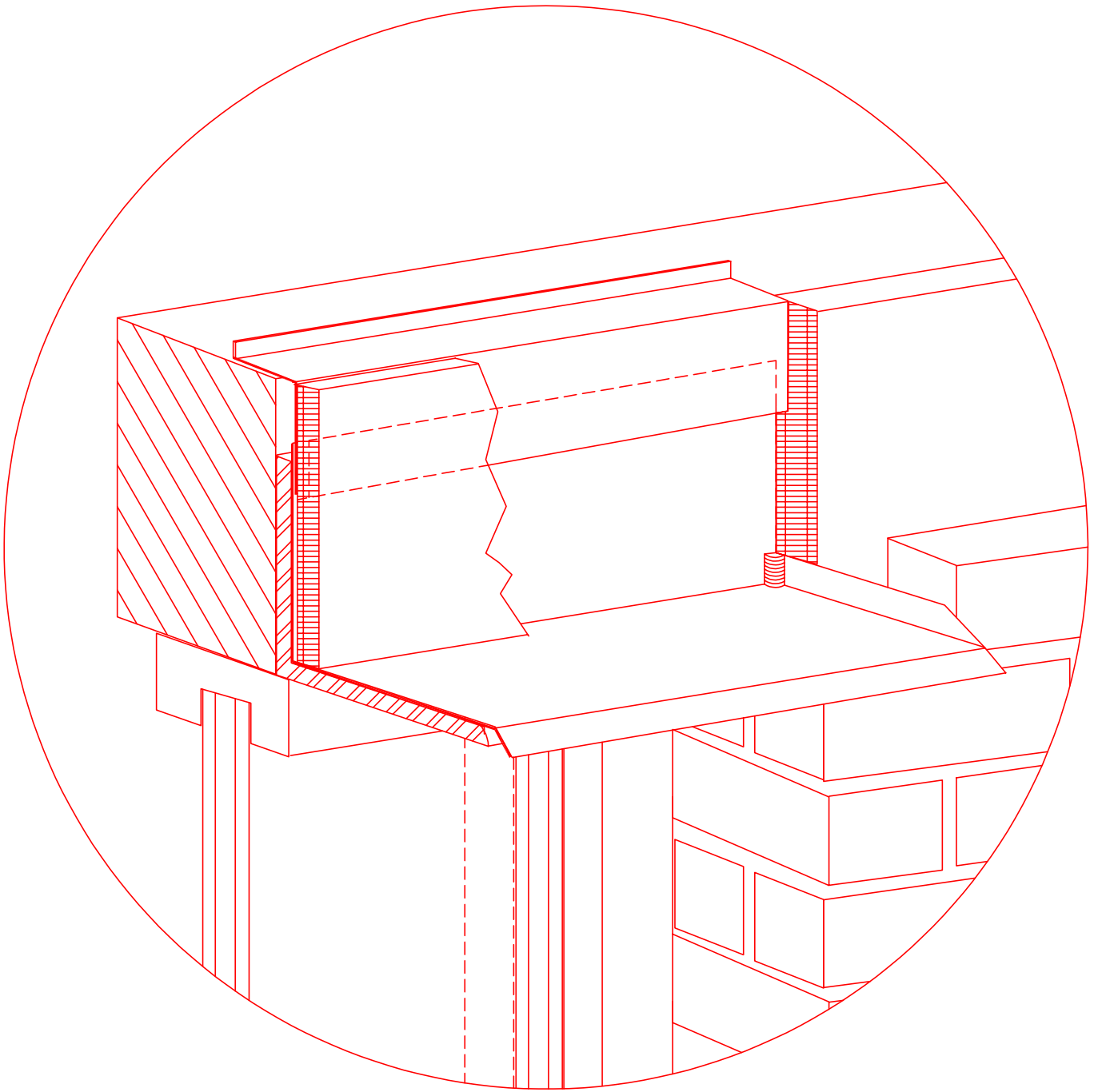

FLASHING END DAM

9. When flashing occurs at a bed joint where mortar is utilized, the flashing should be bedded and covered with mortar before laying the masonry above. (There should be mortar both directly below and above the flashing.) Sealant should not be used in the portion of the bed joint above the flashing, which would tend to hold water in the exterior wall system.
10. Flashing should be installed in such a manner that it breaks the vertical plane of the exterior face of the wall at a level which is lower than any portion of the flashing where concealed. Providing a slight outward slope of the flashing and eliminating penetrations greatly improves reliability of flashing performance.

Through-wall flashing may also be required at the horizontal interface between masonry elements of different materials or masonry elements of the same material but of appreciably different colors, textures or water absorptions. Such need is dependent upon the movement characteristics of the constructed elements and the potential for cracking between them.

Through-wall flashing can generally be eliminated when a minimum 1-1/2" deep brick ledge is provided in the foundation wall to receive the first course of exterior facing material. This assumes rising damp is not a concern, no cold joint in the concrete foundation occurs at the plane of the ledge, and that a bond break (i.e., 15# felt) will be provided at the bottom of the ledge, with the bond breaker trimmed back flush with the face of the masonry after it is laid. The bond breaker is intended to prevent mortar raveling or foundation spalling as differential movement occurs. If perimeter insulation is properly located on the outside of the foundation wall and held down slightly below finish grade, then the metal otherwise needed to cover the top of the exposed insulation may also be eliminated. When metal flashing is needed and used, special precautions may be needed to prevent that metal from being damaged during the construction process.

Through-wall flashing can generally be eliminated when the structural support for the parapet occurs at the top of the roof structure, the typical exterior rain screen wall changes at that location to a typical, solid brick masonry parapet, and the parapet is only a minimal height (16" or less) needed to accommodate the roof membrane used. Use of a flashing at this referenced location may be detrimental under the circumstances outlined, resulting in bond being broken completely through the parapet with just a small masonry mass above the flashing.

## **GUIDELINES FOR PARAPET WALLS**

When such construction is necessary because of code restrictions or similar consideration, the following details should be incorporated:

1. Use identical masonry units throughout thickness.
2. Use solid construction (no cavities.)
3. Separate (isolate) parapet from the main exterior building wall.
4. Place movement joints in the parapet through all courses of masonry down to the roof slab and any adjacent weight support for the masonry.
5. Consider additional movement joints in the parapet over and above what is provided in typical walls below the parapet.
6. Avoid completely covering the inward face of a high masonry parapet with a roofing membrane.

See sketches titled "Typical Roof Edge Detail (stone or concrete cap)," Page III. 21, "Typical Roof Edge Detail (metal cap flashing)," Page XVII. 20, and "Wall Cap Detail," Page XVII. 18.

## **GUIDELINES FOR EXTERIOR GARDEN, PLANTER AND WING WALLS**

Includes all other non-building walls exposed to the elements both sides such as building name signs, traffic barrier walls, privacy walls, protection walls, concealment of garbage and trash storage walls, etc. When such construction is absolutely essential, the following details should be incorporated:

1. Design wall in accordance with the rain screen principle. (See Guidelines for Design and Building of Masonry Resistant to Wind-Driven Rain, Pages II. 1-6.)
2. Vent air spaces top and bottom of wall.
3. Utilize a cast-in-place concrete back-up.
4. Include a continuous, 3/16" single wire or wire assembly, in facing wythe mortar bed joints that occur one course above where the individual ties extend out from the dovetail slots in the concrete. The spacing typically is 16" on center. Corrosion protector to be minimum 1.5 oz/sf hot-dipped galvanized. (These same requirements apply to any face brick wythe that receives its transverse bond/lateral support from ties/anchors connected to the back-up without a continuous wire being present in the exterior wythe portion of the tie/anchor assembly.)
5. Wing walls extending out from the main exterior (heated one side) building walls less than four feet in length, may be built like parapet walls if so desired.

## **GUIDE SPECIFICATION FOR SAMPLE WALL/PANEL OF NEW MASONRY**

As soon as possible after the face brick for this project has been check tested and physical properties found proper, the General Contractor shall proceed to lay up a sample wall/panel at the project site, which includes all elements of the masonry construction. An actual wall sample shall be constructed including: face brick, mortar, back-up, continuous ties, parging, insulation and mechanical connectors, through-wall flashing, weepholes/ventilators, clean outs, and a vertical movement joint; all to ensure compliance with design intent and evaluate quality of materials, techniques, and workmanship.

Face brick shall be from the actual firing for this project and shall reasonably match the appearance of the mounted panel which was used for initial approval of brick appearance. (At the Contractor's option to avoid potential delays, face brick from previous firings may be used for a preliminary sample. No further sample wall/panel will be required if brick from the actual firing for this project are subsequently checked and comply with both the physical property requirements as well as the appearance requirements, and the preliminary sample wall/panel satisfies all other requirements of the contract documents.)

Mortar in sample wall/panel shall comply with specification requirements for exterior masonry. Cleaning of sample wall shall comply with specification requirements for exterior masonry. Sample wall/panel shall be 15 courses high and at least seven bricks long.

Start no brick work until a dry, minimum seven-day old, sample wall/panel of brick work has been viewed and approved for overall appearance by the Owner and A/E. More than one sample wall/panel may thus be required. The approved sample wall/panel shall serve as the standard for brick appearance comparison and shall remain on the job site until brick work is accepted. Remove sample wall/panel and all evidence, thereof, from site upon acceptance of masonry work, unless directed otherwise by A/E.

NOTE: For very large or complicated projects, it may be beneficial to have an independent mason contractor lay up a sample wall/panel prior to the time of project bidding. The sample can then be referenced in the contract documents, and serve as the standard level of acceptability for the masonry work when later under contract, and avoid disputes, particularly on extent of potential cleanliness that must be achieved. If large size masonry units are used (for economy), the required number of units in the sample wall/panel may be reduced.

## **GUIDE SPECIFICATION FOR CONSTRUCTION OF EXTERIOR RAIN SCREEN WALL**

- A. All exterior walls, except where specified otherwise, shall be a rain screen wall type. Build walls with materials of nominal thicknesses and at locations, as indicated on the drawings. All interior wythes shall be constructed first; at least one block course ahead of the outer wythe. The hereinbefore specified general requirements for brick and block masonry work also apply to rain screen wall construction.
- B. The inner and outer masonry wythes of rain screen walls shall be separated by a continuous space 4 inches wide, except for masonry returns indicated at the jambs of openings. Bond the two wythes together with continuous joint wall reinforcing for cavity walls as specified. Individual cavity wall ties, in addition, shall be positioned within 8 inches of the jambs of openings except where the wythes are bonded together with masonry returns at the jambs.
- C. Anchor facing material to columns and spandrels with dovetail inserts as specified. The inner wythe of the exterior wall shall be anchored to the framework, the columns and the underside of spandrels, with dovetail inserts or as otherwise specified and/or as indicated on the drawings.
- D. Cooperate with the insulation trade for the timely delivery of insulation of the various types needed. Walls shall have 16 inch high horizontal strips of rigid insulation specified applied to the cavity face of the inner wythe or concrete, as indicated on the drawings. All insulation joints shall be tongue and groove, tightly butted with vertical joints staggered. Seal all joints in insulation with sealant material recommend by the insulation manufacturer.
- E. After the joint mortar has reasonably set, parge the entire cavity side of the concrete masonry inner wythe with a minimum 3/8 inch thickness of mortar, same as used in joints. Immediately trowel smooth and apply insulation while mortar is still plastic. Press insulation tightly into the parging mortar against the inner wythe between layers of continuous ties, until mortar begins to extrude into the insulation joints. Place insulation clips 24 inches on center horizontally in position on cross wires of continuous ties specified. Secure clips to retain insulation in intimate contact with parging, and provide a 2 inch minimum air space between the insulation and the outer wythe. Where use of plastic disk clips to hold insulation in place is not practical, use equivalent of split 22 gauge corrugated metal ties at same 24 inch spacing. Typically, one leg of the split tie is to be bent up and the other leg is to be bent down, to engage and secure the rigid insulation. Spandrels and columns shall have insulation applied with adhesive as recommended by the insulation manufacturer in lieu of parging mortar, in conjunction with appropriate clips, ties or other mechanical means to hold the insulation in place. Where dovetail anchors pierce insulation applied against the structural frame, seal holes with mastic.
- F. Where indicated on the drawings, build flashing into the wall. Sheet metal flashing and/or flashing receivers will be furnished by the sheet metal trade. Install flashing at the base of all cavities, at all window and door heads and sills, and elsewhere as specified and/or as indicated on the drawings. Set all flashing on a beveled bed of mortar to turn out any water.
- G. Provide open head joints or weep hole ventilators as specified, in mortar joints on the exterior facing wythe on 24 inch centers at the base of all cavities, immediately above shelf angles, ledges, bond beams, lintels, etc. Provide such weep/vent openings wherever flashing is built into exterior masonry walls or other water stops occur, and elsewhere as indicated on the drawings. Provide the same venting at the tops of wall panels, immediately below shelf

angles. Provide 3/8 inch O.D. - 1/4 inch I.D. half tubes for drainage as specified at counterflashing receivers in lieu of other venting. Maintain end of tube 1/2 inch clear of counterflashing. Should sealant occur above any water stop, the sealant shall be periodically broken to form weep holes.

- H. The wall cavity shall be closed off with vertical flashing, rigid insulation and/or sealant at all corners and intermittently to prevent horizontal air movement, as indicated on the drawings. Closures utilizing rigid insulation, closed cell compressible fillers, and/or sealant shall also be provided at the perimeter (horizontally and vertically) around all openings in the wall, where not closed with a lintel or masonry.
- I. The wall & roof junctions shall be closed off (sealed) as specified and/or indicated on the drawings with closed-cell rigid insulation or similar such materials as specified to eliminate air leakage on a long term basis.
- J. Special precautions must be taken to achieve smooth faces on the inside of the cavity space and to ensure that the bottom of the cavity is clean and free of mortar droppings.
  - 1) Lay a full mortar bed for the exterior wythe. A very shallow furrowing of the mortar bed will be permitted, so long as full bed joints without voids can be observed when masonry units are lifted out of their mortar bed to verify bond with mortar. Back bevel mortar bed to minimize mortar dropping into cavity as masonry facing units are placed and aligned.
  - 2) Use temporary wood, metal or fiber strips laid on the continuous joint wall reinforcing and carefully lift them up and out as the work progresses before the next layer of reinforcement is placed.
  - 3) Provide sufficient holes in the cavity to permit visual inspection and all necessary cleaning out of mortar droppings at the base and intermediate support of all cavity walls. As a minimum, every third masonry unit in one wythe of the wall shall be left out at the bottom. The cavity shall be inspected and cleaned out at least twice-a-day during construction of the wall. The inspection and clean-out openings shall be sealed immediately after the cavity is covered above by other construction and the A/E or his delegated representative has subsequently inspected the cavity.
- K. The inner and outer wythes of rain screen walls shall be provided with movement joints as specified or indicated on the drawings. Ensure all movement joints in clay products masonry are cleaned out and made free of mortar at the end of each day's work.

## **GUIDE SPECIFICATION FOR LAYING AND CLEANING OF NEW MASONRY**

- A. ALL MASONRY SHALL BE IN FINAL ACCEPTANCE CONDITION WITHIN 24 HOURS AFTER LAYING AND SHALL BE MAINTAINED IN THAT CONDITION, BY MEETING OR EXCEEDING THE DEGREE OF CLEANLINESS REQUIRED, DEMONSTRATED ON THE APPROVED SAMPLE PANEL.
  
- B. Lay masonry utilizing all necessary care to achieve cleanliness. Remove excess mortar from exposed exterior and interior (stone, clay, concrete and other) masonry surfaces as the work progresses and before it tenaciously adheres to the faces of the masonry. Remove mortar protrusions and smears as masonry units are laid and tooled, as scaffolds are raised, and at the start of the next day's work, leaving the surface of the masonry clean and finished. Contractor may use calcimine brushes, stiff fiber brushes, other similar masonry units, burlap, rags, carpet remnants, rubber floats or other approved means. (Cleaning of masonry the morning after laying by the same masons who laid the masonry the previous day, using stiff fiber brushes with or without water and sand, concentrating on cleaning the field of the masonry units, has also been successfully used to achieve an appearance matching or exceeding the cleanliness of the approved sample panel.) **USE OF CHEMICAL CLEANING OR HARSH PHYSICAL CLEANING WILL NOT BE PERMITTED.** Included as chemical cleaners and prohibited are most manufactured masonry cleaning solutions or compounds. Equipment or methods and techniques utilized, reduced productivity, as well as weather conditions experienced will not relieve Contractor of required compliance.
  
- C. Protection shall be provided to prevent mortar spattering and maintain masonry in a clean condition so that the masonry is satisfactory for acceptance when masonry work is completed. This may require covering portions of finished masonry which is below new work in progress with polyethylene, canvas or other approved means. Cover tops of unfinished walls and new work during inclement weather and at the end of each day's work to prevent moisture entry. Extend covering a minimum of 24 inches down both sides of wall and hold covering securely in place. Hair-pin type devices frequently spaced have been successfully used in the past.
  
- D. No final washdown is required unless removal of earthy construction dirt or dust is necessitated by extremely unusual site conditions.
  
- E. If any masonry is not cleaned as required by these specifications, or if walls have an unsatisfactory appearance upon completion of work, such violations will require additional work by the Contractor for producing acceptable masonry at no extra cost to the Owner. This is not to be construed as a Contractor's option. Procedures must be submitted by the Contractor and samples approved by all other parties to the contract, prior to proceeding with such work.
  
- F. Should the Contractor use or attempt to use chemical cleaning utilizing acid or strong alkali based materials, or should the Contractor use or attempt to use harsh physical cleaning such as sand blasting or pressure water jetting; such actions will be construed as nonperformance causing the Owner damages which shall be liquidated by reducing payment to the Contractor in the amount of \$2.50 per square foot of masonry involved.



**MINIMUM REQUIREMENTS FOR QUALITY OF EXTERIOR FACE  
BRICK MASONRY UNITS ON PROJECTS WITH MORE THAN 15,000  
NEW FACE BRICK REQUIRED**

1. **Materials:** Face brick shall be made from fire clay, shale or mixture thereof and burned and manufactured to comply with all applicable requirements of the State Building Code and ASTM C216, Grade SW, Type FBS, typically cored; except where superseded by more stringent requirements mentioned herein.
2. **Physical Properties:** All face brick shall be free from cracks, laminations and other defects or deficiencies, including coatings, which may interfere with proper laying of the brick or impair the performance or permanence of the construction. Brick which have been significantly surface-coated prior to firing or siliconed, or similarly surface-treated after firing are not allowed. All face brick shall have physical properties that also conform to the following specific requirements:

Test	Units	Average of 5 Bricks	Individual
Compressive Strength	psi	8,500 min.	7,500 min.
Modulus of Rupture (net area)	psi	1,200 min.	800 min.
Water Absorption (24 hr. cold)	%	--	8 max.
Initial Rate of Absorption	grams per min. per 30 sq. in.	5 min.	3 min.
Initial Rate of Absorption	grams per min. per 30 sq. in.	20 max.	25 max
Efflorescence			None
Autoclave Expansion (age of 1 month)	%	0.10 max.	0.20 max.
Must meet one of the following requirements:			
C/B Ratio	--	0.76 max.	0.78 max.
* Water Absorption (24 hr. cold)			
Fire Clay	%	--	2 max.
Shale	%	--	5 max.
** Frost Resistance Durability Factor	--	--	70 min.
* For mixtures of fire clay and shale, prorate values listed as requirements			
** DF = $3.2/PV + 2.4 P3$			
DF = Frost-Resistance Durability Factor			
PV = Total Intruded Pore Volume (cm <sup>3</sup> /g)			
P3 = Pre Volume with Diameters Greater than 3μm (%)			

3. **Testing Standards:** Sampling and testing of face brick is to be done in accordance with ASTM C67, except as follows. Brick may be heated in a ventilated oven to 900F and, upon retesting, shall still comply with all the specific physical property requirements and with results similar to that obtained prior to heating in the oven. Testing of brick for moisture expansion by autoclaving is to be conducted in accordance with the time, temperature, pressure, and moisture conditions required by ASTM C151. Pore size distribution of brick is to be determined by mercury intrusion porosimetry using applicable procedures of ASTM D4284. Pore volumes are to be measured between pore diameters of 100μm and 0.01μm using a porosimeter. Pressure readings are to be converted to pore diameters with the angle of contact of the mercury assumed at 130 degrees.

## **GUIDELINES FOR SELECTION OF FACE BRICK MASONRY UNITS**

NO STATED ALLOWANCES WILL BE PERMITTED IN THE SELECTION PROCESS

Projects with more than 50,000 brick (major additions, large buildings, and similar such construction).

**A. Brick Vendor:**

1. Propose only brick which appear to fully comply with the Division of Facilities Development quality guidelines, Page X. 1.
2. Submit test reports less than two years old on complete physical properties of brick under consideration to Architect/Engineer. (An autoclave expansion test is not required.)
3. Submit brick from recent firing to Division of Facilities Development approved laboratory for preliminary testing.
4. Offer brick to Architect/Engineer only if items 1-3 indicate compliance with quality guidelines.

**B. Architect/Engineer:**

1. Provide brick vendors with size, color, shade, blend and surface texture desired of brick for project.
2. Consider only brick meeting requirements imposed on brick vendors.
3. Select a minimum of three brick having acceptable appearance requirements and approval of Division of Facilities Development and Owner. Obtain test reports less than one year old from brick vendors on complete physical properties for brick selected, before listing them in the bid documents. (An autoclave expansion test is not required.)
4. Qualify brick listed in the bidding documents to the extent that such brick have been offered to the Owner as face brick which meet the quality guidelines and also have the appearance approved by the Owner.
5. Require, by means of the bidding documents, that the face brick manufacturer, vendor and/or supplier all be responsible to the General Contractor for meeting requirements of the quality guidelines.
6. Provide, by means of the bidding documents, for final sampling and testing of the face brick intended for the project, upon total completion of firing. (At such time, the Division of Facilities Development will arrange for a timely sampling and check testing of the face brick.)

Projects with 15,000 - 50,000 brick (small additions, small buildings, and similar such construction).

- A. Vendor to submit test reports less than two years old on physical properties of proposed brick to Architect/Engineer. (An autoclave expansion test is not required.)
- B. Vendor to submit brick to the Division of Facilities Development approved laboratory for check-testing.
- C. Architect/Engineer to list brick (at least three desirable, minimum of two) having acceptable appearance requirements and final approval of Division of Facilities Development and Owner prior to bidding.
- D. Contractor to satisfy himself and be responsible for compliance of brick with Division of Facilities Development Guidelines. (Contractor to propose his choice of Architect/Engineer listed brick.)

Projects with 1,000 - 15,000 brick (minor remodeling, new elevator stair towers, and similar such construction).

- A. Vendor to submit test reports less than five years old on physical properties of proposed brick to Contractor. (An autoclave expansion test is not required.)
- B. Contractor to satisfy himself and be responsible for compliance of brick physical properties with code and ASTM.
- C. Contractor to obtain brick which match the appearance of those existing in the building.
- D. Architect/Engineer to approve samples (after bidding) for appearance.

Projects with less than 1,000 brick (miscellaneous repair work).

- A. Contractor to obtain brick which match the appearance of those existing in the building. (An autoclave expansion test is not required.)
- B. Architect/Engineer to approve samples (after bidding) for appearance.

**GUIDE SPECIFICATION  
FOR FACE BRICK MASONRY UNITS ON PROJECTS WITH MORE  
THAN 50,000 NEW FACE BRICK REQUIRED**

- A. Materials
- B. Physical Properties
- C. Testing Standards
- D. Size
- E. Quantity
- F. Storage
- G. Approved Appearance
- H. Ordering
- I. Sampling & Testing
- J. Delivery, Unloading and Storage

- A. Materials: Face brick shall be made from fire clay, shale or mixture thereof and burned and manufactured so as to comply with all applicable requirements of the State Building Code and ASTM C216, Grade SW, Type FBS, typically cored; except where superseded by more stringent requirements mentioned herein.
- B. Physical Properties: All face brick shall be free from cracks, laminations and other defects or deficiencies, including coatings, which may interfere with proper laying of the brick or impair the performance or permanence of the construction. Brick which have been significantly surface-coated prior to firing or siliconed, or similarly surface-treated after firing are not allowed. All face brick shall have physical properties that also conform to the following specific requirements:

Test	Units	Average of 5 Bricks	Individual
Compressive Strength	psi	8,500 min.	7,500 min.
Modulus of Rupture (net area)	psi	1,200 min.	800 min.
Water Absorption (24 hr. cold)	%	--	8 max.
Initial Rate of Absorption	grams per min. per 30 sq. in.	5 min.	3 min.
Initial Rate of Absorption	grams per min. per 30 sq. in.	20 max.	25 max.
Efflorescence			None
Autoclave Expansion (age of 1 month)	%	0.10 max.	0.20 max.
Must meet one of the following requirements:			
C/B Ratio	--	0.76 max.	0.78 max.
*    Water Absorption (24 hr. cold)			
Fire Clay	%	--	2 max.
Shale	%	--	5 max.
**    Frost Resistance Durability Factor	--	--	70 min.
* For mixtures of fire clay and shale, prorate values listed as requirements			
** DF = 3.2/PV + 2.4 P3			
DF = Frost-Resistance Durability Factor			
PV = Total Intruded Pore Volume (cm <sup>3</sup> /g)			
P3 = Pre Volume with Diameters Greater than 3µm (%)			

- C. Testing Standards: Sampling and testing of face brick are to be done in accordance with ASTM C67, except as follows. Brick may be heated in a ventilated oven to 900F and, upon retesting, shall still comply with all the specific physical property requirements and with results similar to that obtained prior to heating in the oven. Testing of brick for moisture expansion by autoclaving is to be conducted in accordance with the time, temperature, pressure, and moisture conditions required by ASTM C151. Pore size distribution of brick is to be determined by mercury intrusion porosimetry using applicable procedures of ASTM D4284. Pore volumes are to be measured between pore diameters of 100 $\mu$ m and 0.01 $\mu$ m using a porosimeter. Pressure readings are to be converted to pore diameters with the angle of contact of the mercury assumed at 130 degrees. The General Contractor shall make necessary brick available when requested, for physical tests conducted by a testing laboratory selected and employed by the Owner to check for compliance of brick with the specifications. In the event the test results show the brick to be in noncompliance with the specifications, the General Contractor shall reimburse the Owner for the testing costs.
- D. Size: Except where drawings required otherwise, face brick shall be of (Modular, Standard or other) size and shall have dimensions of (N" x N" x N"). Size differences between brick shall not exceed three percent in any dimension.
- E. Quantity: Provide face brick required to complete brickwork as indicated on the drawings and as herein specified. Size of brick is specified hereinbefore. Where face brick are used in a wall both faces of which are exposed to the weather, the wall shall be built of the same face brick throughout. Include a minimum of (1/2 percent) extra typical face brick, to be turned over to the Owner upon completion of the project. Provide special brick where indicated on the drawings or otherwise required for a complete installation, with same size, surface texture and color range on all exposed surfaces to match adjacent brick. Include solid units, no core holes, for trim uses and where core holes might otherwise be exposed. Also, include special shape stretcher and corner brick at shelf angles. Contractor to note ASTM C216 allows up to five percent broken brick, unless otherwise stipulated.
- F. Storage: All brick shall be stored at the site of manufacture and/or the project site for a minimum time period of (...4 weeks or more...) after completion of manufacture and before being incorporated into the structure.
- G. Approved Appearance: The following face brick have been offered to the Owner as face brick meeting the physical property requirements specified hereinbefore. Any one of the following face brick also have the appearance approved by the Owner for this project.
- 1.
  2. (Minimum number of vendors and manufacturers required for good competition)
  - 3.
- H. Ordering: As soon as possible after award of contract, the General Contractor shall place the order for any one of the previously listed face brick, so that it can be delivered in sufficient time to avoid construction delays. The General Contractor shall satisfy himself and be able to show that the brick he proposes comply fully with the requirements of the contract documents in all respects. The General Contractor shall also make the face brick manufacturer, vendor and/or supplier responsible to the General Contractor for meeting these specifications. Transportation shall include shrink-wrap weather protection or other protection as required by the General Contractor.
- I. Sampling and Testing: Upon completion of firing of all face brick for this project and notification by the General Contractor, the Owner will have made an impartial sampling and check testing of such face brick. No face brick shall leave the site of manufacture for use in this project until after this sampling and check testing is completed and indicates that the face brick comply with the physical property requirements of the contract documents. The

General Contractor will be notified immediately of the results of the sampling and check testing. Brick approved and needed for use on this project shall not be sold to others, and only such brick shall be shipped to the project site. In the event the tests indicate noncompliance, the face brick are automatically rejected.

- J. Delivery, Unloading and Storage: Upon delivery of brick to the job site, the General Contractor shall immediately have each load sampled and compared with the approved sample, and shall report any deviations immediately. All units used in the work shall conform to requirements specified herein. Any improper brick to be culled out and immediately removed from the site. Brick shall be resorted or culled as necessary, especially when plant palletted, to avoid spotty or irregular ranges of color or texture in the finished wall. The responsibility for meeting these specifications and the approved sample rests with the General Contractor. Brick shall be carefully unloaded and neatly stacked on or near the project site, undamaged, and adequately protected at all times.

# **MINIMUM REQUIREMENTS**

## **FOR ARCHITECTURAL PRECAST CONCRETE**

Restrictions (Criteria of Acceptability) Include:

1. A/E Responsible for In-Place Design
2. Eligibility of Bidders Outlined
3. Prefabrication Meeting Required with All Parties in Attendance
4. Bolted Connections Used in General
5. 5/8" Minimum Diameter, Stainless Steel Bolts
6. 3/8" Minimum Thickness Connection Hardware, Minimum Hot-Dip Galvanized After Fabrication
7. All Cast-In Metals, Including Reinforcing Bars and Mesh, Minimum Hot-Dip Galvanized After Fabrication or Epoxy Coated
8. 1 1/2" Minimum Coverage Over Reinforcing
9. Concrete Quality
  - 5,000 PSI Minimum 28-Day Compressive Strength
  - 3" Maximum Slump
  - 3-6% Entrained Air
  - 6% Maximum Absorption
10. 7-Day Minimum Moist Curing
11. Form Release Agent and Similar Contaminants Removed From Edges of Elements to Receive Sealant
12. Surfaces to Receive Sealant - Not Exposed Aggregate
13. Destructive Testing Used To Check Quality
14. Cracking and Unsightly Appearance - Not Acceptable
15. Waterproofing - Not Allowed
16. All Wash Surfaces to be Sloped, and Drips Provided In Bottom of Elements - where exposed
17. Detailed Information Provided for Masonry Precast Elements
18. Example of Approved Appearance Available

## **MINIMUM REQUIREMENTS**

### **FOR EXTERIOR INSULATION AND FINISH SYSTEMS (EIFS)**

1. Use a polymer modified (PM) hard coat EIFS with embedded, chemically-coated, glass-fiber mesh reinforcing. (List minimum thickness for both base and finish coats as well as sealer, temperature limitations for installation and curing, etc., and manufacturers/installers who have the capability to provide such an EIFS.)
2. Use tongue and groove, extruded polystyrene insulation in the EIFS. (List minimum thickness, density and other properties required, and advise of surface finish and texture necessary at time of installation.)
3. Fasten the entire system mechanically into a firm, sound, moisture-resistant, non-corrosive backing. (Outline spacing or minimum numbers, sizes and types of nonconductive fasteners needed and percent that pass through both mesh and insulation. Supplement attachment with mastic/adhesive recommended by insulation manufacturer.)
4. Provide proper location and frequency of joints for movement in the system with such joints extended through all portions of the system, including insulation, back to the substrate. (Provide minimum spacing and location requirements.)
5. Provide corrosion-resistant metal flashing protection sloped down and away with continuous drip on the top surface, and metal/plastic drip on the bottom, outer surface also extended out beyond the EIFS, wherever the EIFS is projected out beyond the typical face of the wall.
6. Provide positive closure of the EIFS, with appropriate glass-fiber mesh backwrapping and/or necessary trim, at through-wall openings, movement joints, and termination of the system with other construction.



## **GUIDE SPECIFICATION FOR MORTAR**

### **1. MORTAR MATERIALS**

- A. Portland Cement: Shall conform to ASTM C150, Type I. Only one brand and kind of portland cement from one source shall be used for the work unless prior written approval is obtained from the Architect/Engineer. Brands are subject to approval of the Architect/Engineer based upon the mortar color desired and obtainable by use of the various brands readily available. No white cement or nonstaining cement will be required.
- B. Lime: Shall be pressure-hydrated, non air-entrained and conform to ASTM C207, Type S. Lime for use in exterior walls shall be soaked for at least 24 hours immediately prior to using and added as a putty to the mix.
- C. Masonry Cement: Shall conform to ASTM C91.
- D. Masonry Sand: Shall be clean, sharp, free from loam, silt, vegetable matter, salts and other injurious substances, and shall conform to ASTM C144, except that sand for mortar in 1/4 inch wide joints shall pass a No. 16 sieve. Sand is further subject to approval of the Architect/Engineer, based on mortar color desired and obtainable by use of local sands readily available, and shall be from one source.
- E. Water: Shall be potable, fresh, clean, clear, and free of injurious amounts of oil, acid, alkali, salts, organic matter or other detrimental substances, and handled in clean containers.
- F. Plasticizer: Not allowed.
- G. Waterproofer: Not allowed.
- H. Coloring Admixture: Not allowed.
- I. Other Admixtures: Shall not be used at any time and will not be knowingly approved. Use of special air-entraining admixtures, chlorides or nitrates, with or without approval, will be sufficient cause to require removal and replacement of all masonry work containing or treated with same.
- J. The autoclave expansion of the cementitious portion of the mortar materials, when mixed in proportions required under "mortar mixes," shall not exceed one-half percent when tested according to ASTM C151. The air content of any mortar required under "mortar mixes" shall not exceed five percent when tested according to ASTM C231 and/or ASTM C173.
- K. Partial premixed mortar materials will be considered for approval when each requirement of the individual materials is complied with and is so stated on the package, along with proportions and quantities. The lime soaking requirement for exterior walls will be waived in the event of such use. When masonry cement mortar is used for interior work, the five percent maximum air content requirement will be increased to eighteen percent.

## 2. MORTAR MIXES

- A. Measure materials for mortars by volume, in a manner whereby proportions can be controlled within two percent. Mix cementitious materials and masonry sand dry. Add lime putty for exterior mortar, when lime is not prepackaged with cement, and then water to bring to proper consistency for use. Mix materials in the approved type machine mixer of adequate capacity for 3 to 5 minutes after all materials have been introduced, until materials are evenly distributed throughout the batch and the mixture is uniform in color with a workable consistency.
- B. Use maximum water consistent with good workability and freedom from smearing the face of masonry work. Use no mortar that has stood more than one hour after initial mixing. Mortar less than one hour old shall be reasonably retempered as necessary to maintain its workability, but used before it is one hour old or otherwise discarded. No anti-freeze ingredient or contaminate of any type will be tolerated.
- C. Mortar for Stonework and Bearing Walls: Shall be ASTM C270, Type S, Cement-Lime Mortar. (1:1/2: 4 1/2).
- D. Mortar for Brick and Concrete Block in Nonbearing Exterior Walls: Shall be ASTM C270, Type N, Cement-Lime Mortar. (1:1:6).
- E. Mortar for Concrete Block in Nonbearing Interior Partitions: Shall be ASTM C270, Type N, Cement-Lime or Masonry Cement Mortar, (1:1:6) or (1:3), or Type O, Cement-Lime Mortar. (1:2:9).
- F. The proportions listed above with three figures given are portland cement, lime, damp loose sand, respectively by volume, and with two figures given are masonry cement, damp loose sand, respectively by volume. The proportions are listed only as samples for the required type mortars and shall be modified as necessary, within tolerances, to suit the particular masonry sand being used.

## **MINIMUM REQUIREMENTS FOR SEALANTS IN EXTERIOR WALLS OF NEW BUILDINGS**

### **A. DESIGN**

1. Depth of sealant at the center of its cross section should be uniform and approximately 1/2 width of sealant, with no depth less than 1/3 the width. Depth of sealant at bond interface should be uniform and approximately equal to width of sealant with no depth less than 3/4 the width, except where a bond breaker is used. (See sketches attached titled "Proper Joint Configuration," Page XVI. 2.)
2. Whenever a caulked joint is required between two surfaces which are at approximately 90° to each other, sealant should be provided with proper backing to obtain the reduced depth of the sealant required at the center of its cross section.
3. Joints in general should be 3/8" wide unless indicated otherwise on the drawings, with no joint less than 1/4" wide. (Movement joints in clay products masonry should be a minimum of 1/2" when constructed.)
4. Sealant should be interrupted at weep hole ventilators or similar construction where a continuous sealant application would tend to trap water in the wall.

### **B. MATERIAL**

1. Polyurethane sealants should be used with porous materials and for joints between porous and nonporous materials.
2. Silicone sealants should be used with nonporous materials. (Silicone sealants are not paintable.)
3. Joint primer should be unpigmented and durable, made by manufacturer of sealant used, and should be specifically designed as a prime coating for material(s) on which the compound will be applied.
4. Joint subcaulking material should be nonstaining, resilient, closed-cell, polyethylene foam rod stock, compatible with sealant and primer. Joint subcaulking material should be sized to be under approximately 25% or less compression when in final position, except for joint configurations requiring 1/2 round or 1/4 round rod stock, which should be secured in position with a nonsmear adhesive.
5. Bond breaker should be polyethylene tape, or other approved materials or coated materials providing a bond breaker on the exposed side, with a nonsmear adhesive on the contact side.
6. Cleaner should be solvent material which will not etch or mar metal finishes, leaves no residue, and the product of a nationally recognized manufacturer.

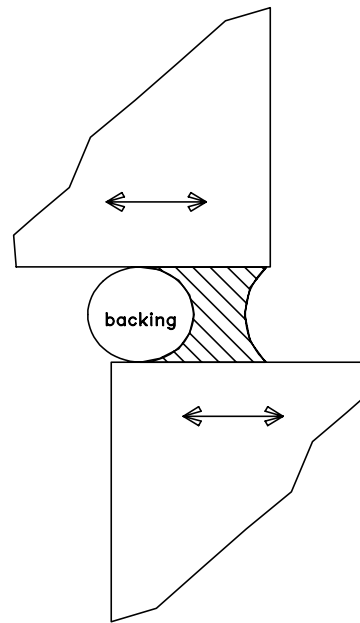
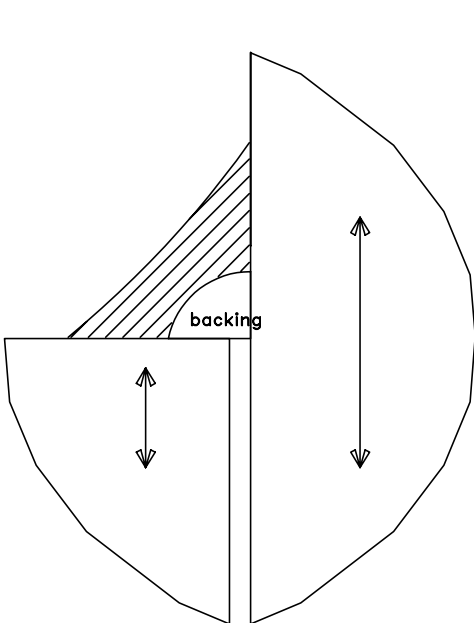
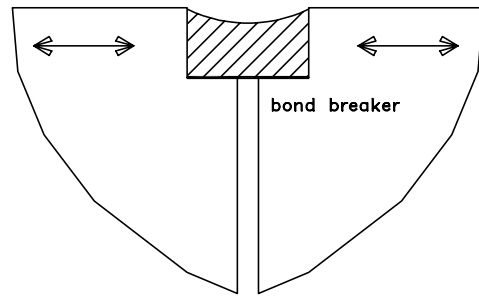
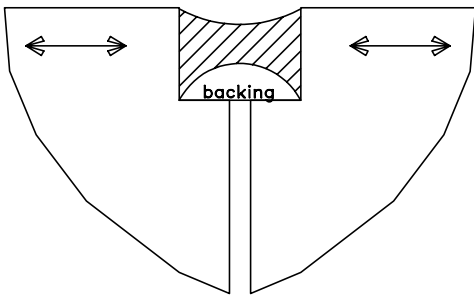
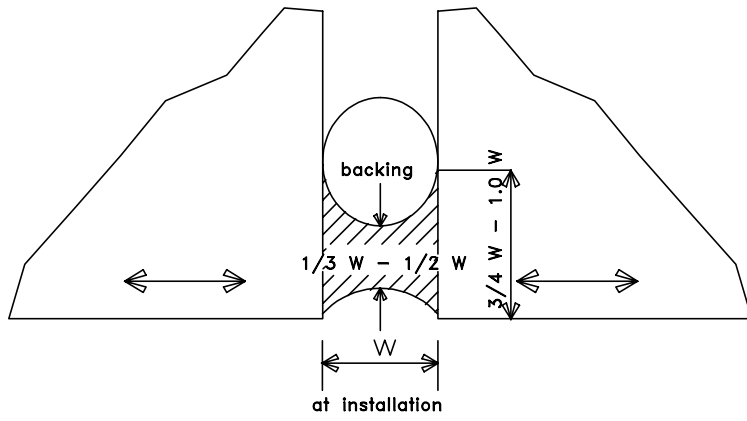

PROPER SEALANT JOINT CONFIGURATION

## C. CONSTRUCTION

1. Prior to commencing work, a pre-installation conference should be held at the project site with the contractor, subcontractor, sealant manufacturer's technical representative, and the construction representative in attendance. (Samples of typical work should be installed prior to such time so that the details of all typical sealant joints required can be evaluated.)
2. Provisions should be made to afford the construction representative actual close up inspection of all sealant and related work.
3. All movement joints in masonry should be open and cleaned out full depth of the masonry wythe before any sealant work commences. (Specially-detailed movement joints in concrete products masonry may be an exception.)
4. All porous materials should be primed as part of joint preparation, and nonporous materials treated as recommended by the sealant manufacturer.
5. Movement joints in clay products masonry should be caulked when dry and temperatures are 70F or above. Other joints may be caulked when surfaces are dry and air temperatures are over 40F.
6. Completed, caulked joints should be neat and watertight with sealant material securely bonded to sides of joints (interfaces) and unbonded to backing. (Visible gassing or bubbling of sealant material should not be tolerated.)

# **COMMENTARY ON MINIMUM REQUIREMENTS FOR EXTERIOR WALLS ON MAJOR PROJECTS INVOLVING NEW BUILDINGS**

## **INTRODUCTION**

This commentary provides information to allow a more knowledgeable decision in the selection of design, material, construction methods and craftsmanship for the exterior building envelope of major state projects involving new buildings or major additions thereto.

Included is background data used in the development of the Minimum Requirements and Guides, Pages I. 1-2, along with insight on why the involved items were adopted. It is an outgrowth of the knowledge and experience gained by field review of exterior building envelopes. The underlying premise is to highlight those things based primarily on performance longevity that either work well or work poorly. This commentary on the minimum requirements and guides is intended to portray the leading-edge-of-technology (former state-of-the-art) knowledge. Graphic details, guide specifications and other examples are also provided to supplement this commentary.

All the information contained in both standards and guides, as well as in the commentary, will be periodically reviewed and updated as additional facts become available that warrant changes.

Reference: Envelope Design Guidelines for Federal Office Buildings: Thermal Integrity and Airtightness, National Institute of Standards and Technology, March 1993.

## A. DESIGN

### 1. GENERAL DESIGN TO BE PROVIDED:

a. **Rain Screen Principle:** (See “GUIDELINES FOR DESIGN AND BUILDING OF MASONRY RESISTANT TO WIND-DRIVEN RAIN,” Pages II. 1-6.) This type of wall system is superior to other types of exterior walls by virtue of resistance to rain penetration and the transmission of heat, fire, and sound. Numerous repeat problems of the past related to exterior water penetration and condensation have virtually been eliminated by utilization of this knowledge and its application in the design and construction of new exterior walls. The exterior facade avoids reliance on the need for sealants or other means to create a semipermanent, watertight seal at the exterior face to resist water penetration. Such a wall system also greatly minimizes the potential for face brick or mortar deterioration by reducing the pressure differential across the face of the wall, thus lowering the likelihood of brick or mortar saturation in combination with freeze-thaw cycling. The wall system also provides two surfaces to which moisture can readily migrate and be evaporated or sublimated.

Common design deficiencies include failure to close off the air cavity periodically by appropriately locating and detailing compartmentalization to overcome adverse wind tunnel and stack effects, failure to require a nominal 2" air cavity which can then be kept reasonably clean, and failure to detail venting of the cavity top and bottom at each floor level which helps accomplish equalized air pressure between the cavity and the outside.

Common construction deficiencies include failure to install an adequate air barrier inward of the air cavity for accommodation of air pressure differential between the cavity and the inside, failure to provide positive slope on flashing to direct any moisture out, and failure to prevent or clean out mortar droppings at the base of the cavity which otherwise inhibits desirable equalization of air pressure between the outside and the cavity. Fabric, pea gravel or similar elements at the base of the cavity is not an acceptable substitute for a clean cavity.

It is desirable to provide details for proposed methods of closing off the air cavity at or near all outside and inside building corners and intermittently between corners. Intermediate vertical compartmental closures should occur no greater than twice the spacing of movement joints in clay products masonry. Consider flashing installed vertically at movement joints to block off the air cavity. As an alternative, consider wider pieces of insulation to close off cavity directly at corners, with end of insulation butt tight to adjacent insulation. Indicate closed cell backing rod between closure piece of insulation and back of brick wythe. Also (See drawings titled “Vertical Flashing Closure Detail,” “Corner Wall Closure Detail,” and “Intermittent Wall Closure Detail,” Pages XVII. 2, 3 & 4.)

b. **Masonry back-up:** Concrete masonry back-up is intended for the exterior wall system primarily for its ease in minimizing air leakage. This is ultimately accomplished with the use of dry, aged concrete masonry units, and with parging and rigid insulation required, which provides both the needed air barrier and vapor retarder. An acceptable alternate is a properly designed and constructed precast concrete back-up system with adequate long term seals. A common problem is the providing of flashing reglets into concrete columns. The flashing and its receiver reglet must be continuous - not interrupted at columns or any other irregularities.

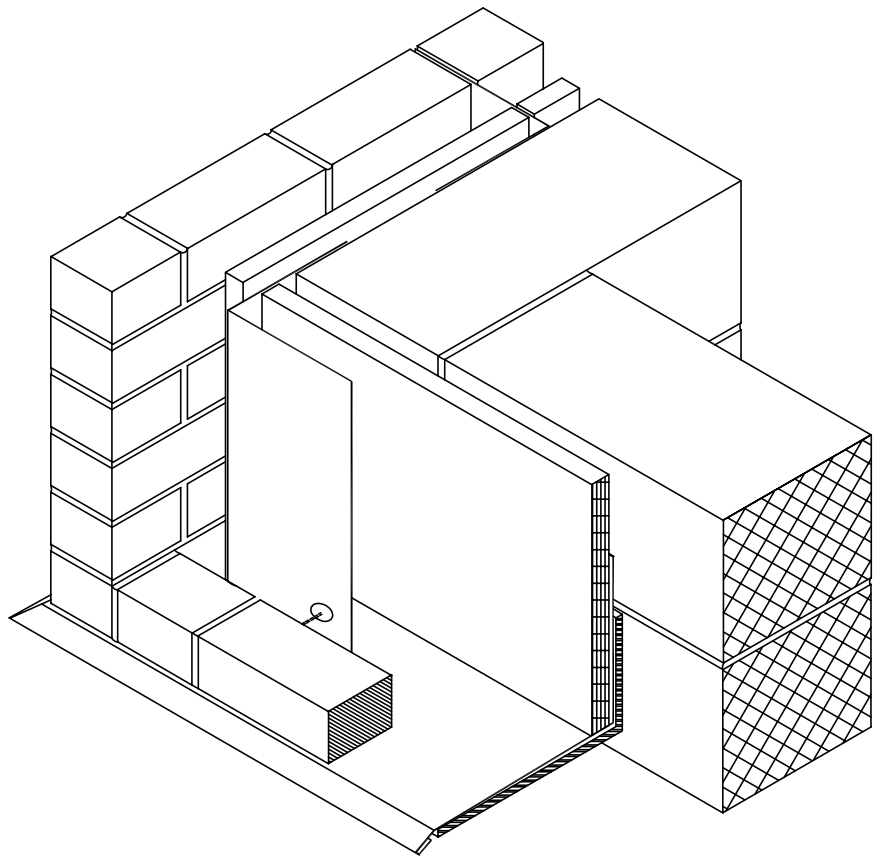
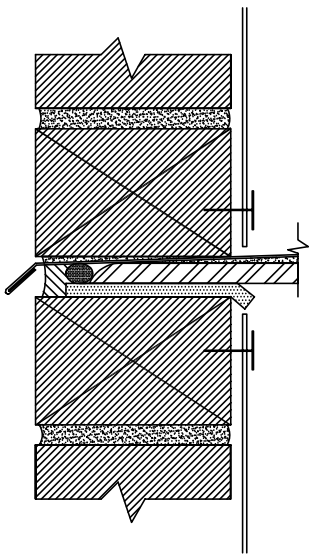
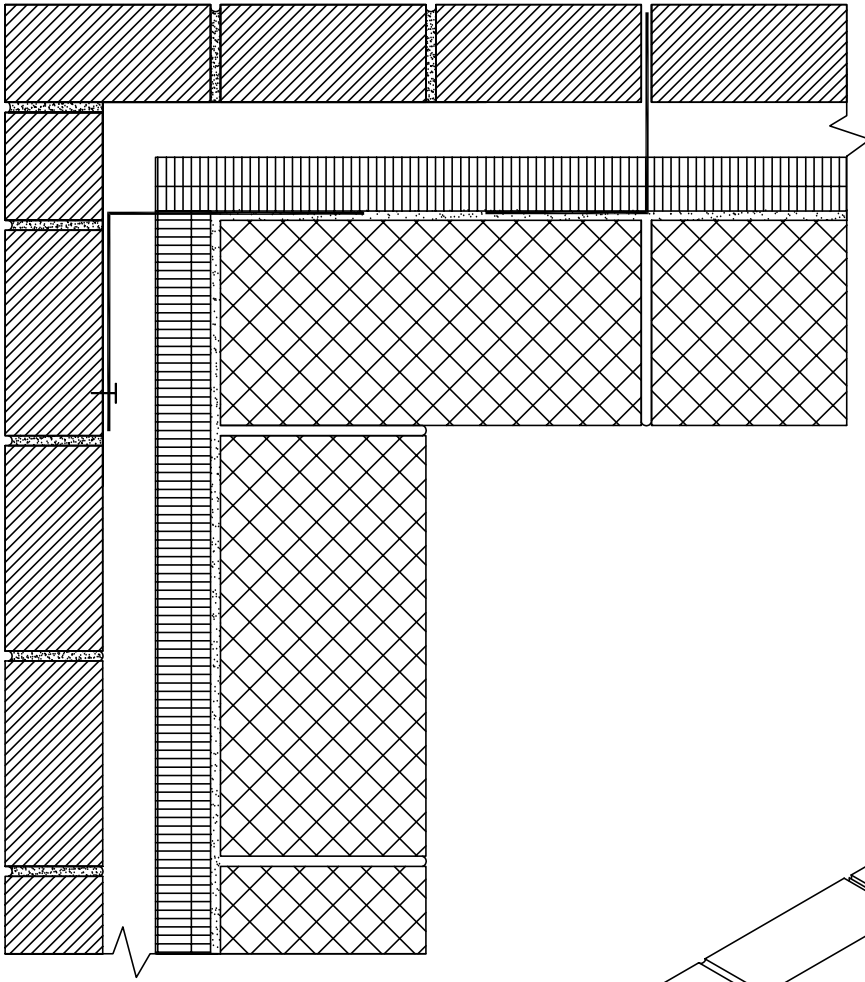

VERTICAL FLASHING CLOSURE DETAIL



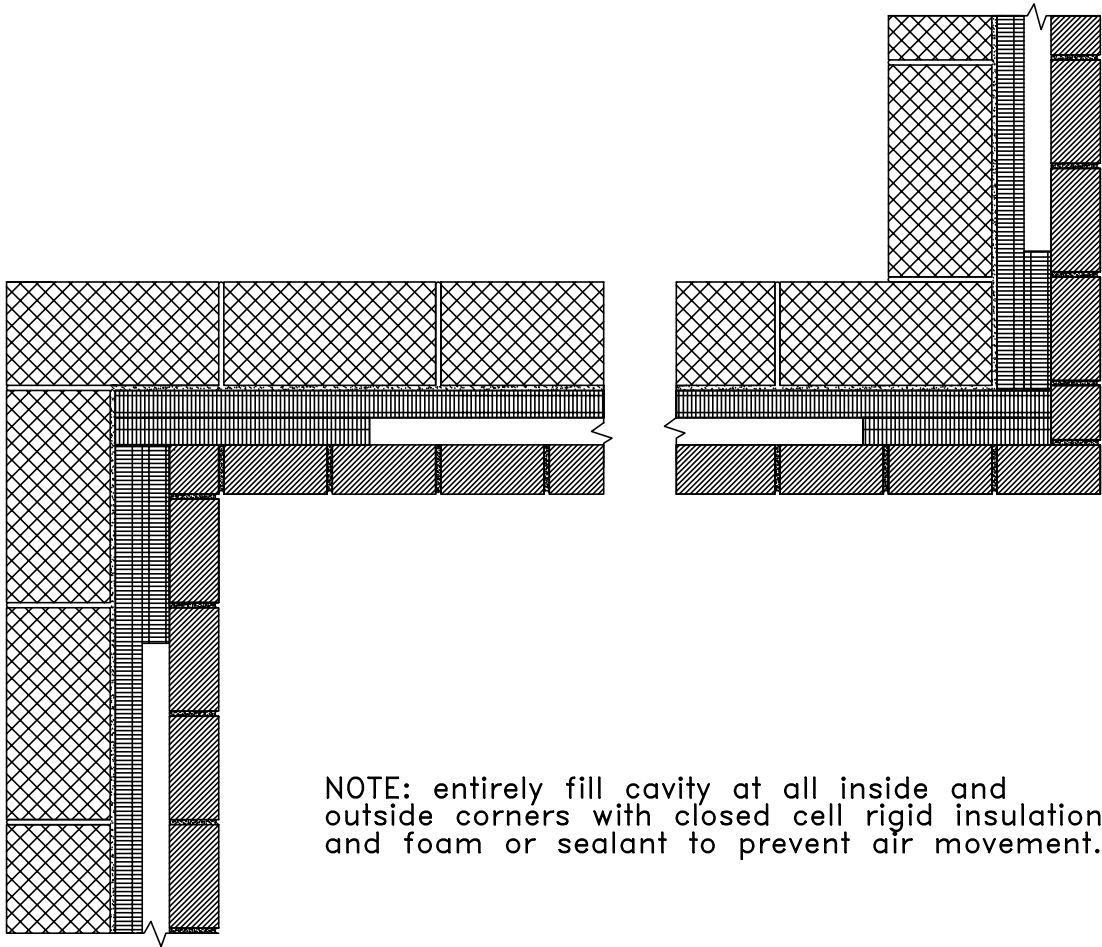

NOTE: entirely fill cavity at all inside and outside corners with closed cell rigid insulation and foam or sealant to prevent air movement.

CORNER WALL CLOSURE DETAIL

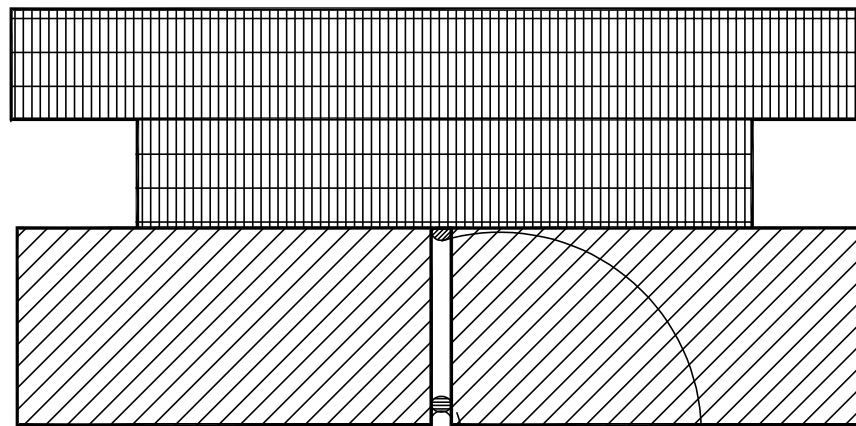
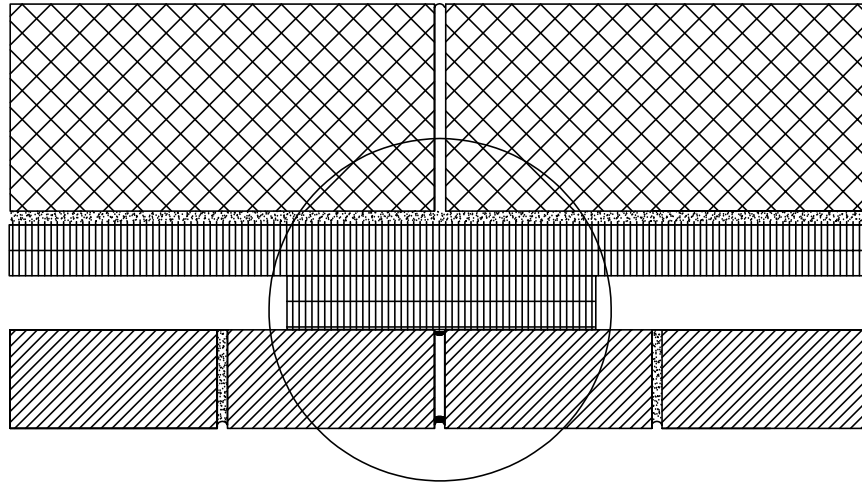

sealant & backer rod

foam or sealant

INTERMITTENT WALL CLOSURE DETAIL

A stud and sheathing back-up system should not be used except in retrofit or penthouse additions to existing structures where added dead load would be a significant concern. It is acknowledged that a steel stud back-up can be designed and built to achieve its component requirements for a rain screen wall, as shown by our Canadian neighbors. Such accomplishment, however, is very difficult to achieve without inordinate inspection. When installed properly, a steel stud back-up loses its apparent economic advantage. A steel stud back-up has allowed numerous problems to develop. Most are moisture related. Water penetration of the exterior facing during moderate weather and air leakage of warm, moist interior air around the back-up with resulting condensation during cold weather has too frequently occurred. This is the moisture source which may ultimately lead to corrosion of critical metal components in an exterior wall system.

Common design deficiencies with concrete masonry back-up include lack of definition for and where normal weight or light weight units may be used. Common construction deficiencies include an inadequate closure between the concrete masonry back-up and the surrounding structure. Sound absorbing concrete masonry units (having slots molded in the face of the units leading to the core holes) should not be used in an exterior wall system because of their potential for air leakage and resultant problems.

c. **Protected (unexposed) frame:** The structural frame is best constructed with its exterior face in the same plane as the exterior face of the concrete masonry back-up. This allows identical treatment for installing the parging (air seal), insulation, air cavity and facing material. An alternate location, where desired for appearance purposes, is to hold the exterior face of the frame back from the exterior face of the facing wythe in an amount equal to the depth of an exterior insulation and finish system when it is to be applied. It is generally difficult to achieve the necessary air seal at the interface between a steel frame and the back-up masonry.

Poor results have been experienced with building designs that utilized portions of the structural frame exposed directly to the elements. Cracking of concrete, water penetration and rusting of reinforcing have frequently resulted. Problems with condensation and excess energy consumption have similarly occurred.

Putting the frame, back-up and any finish materials on the inside of the insulation, air barrier and vapor retarder, has numerous benefits. Such installation maintains the finished construction in a controlled environment that is provided and maintained on the inside of the building. Such construction should help prevent water penetration, yield a extremely stable frame and back-up system under the most severe exterior thermal and moisture changes, prevent condensation from occurring, and allow for the then minor differential movement between dissimilar materials. The minimal thermal and moisture changes thus drastically reduce the movements that otherwise must be anticipated and the resultant potential for cracking. If the insulation were to be placed on the inside of the back-up system, it then subjects the back-up to appreciably more movement and potential freeze/thaw deterioration as well.

For these same reasons, it is preferable for the insulation to be placed on the outside of the foundation wall. Where the adjacent grade fairly closely follows the brick ledge, the insulation can be held down slightly below grade without any appreciable loss in thermal efficiency. This latter alternative will also eliminate the need for any flashing at the foundation when a brick ledge is provided, to cover the top of the insulation.

d. **Cast-in-place concrete foundations:** A concrete foundation wall is overwhelmingly preferred for major projects because of the potential problems it eliminates. For multiple levels below grade, a structural analysis dictates reinforced concrete or reinforced masonry. Concrete masonry basement walls are prone to long term leakage and deterioration, requiring extensive, difficult maintenance. Cast-in-place concrete takes far more abuse from the construction process than does concrete masonry, and reduces the potential for rising damp entering the exterior facing wythe.

e. **Air/vapor barrier on warm side of wall:** In northern climates, no barrier or a wrong location may lead to condensation or worse problems. The vast difference between a barrier to air leakage and a retarder to vapor diffusion should not lead to “vapor confusion”. Air leakage is usually much more destructive to the integrity of the exterior wall system than is vapor transmission. In fact, air leakage into/through exterior walls in northern climates may be the leading cause of wall problems. Interior moisture escape and subsequent frost action in the exterior wall system can be devastating.

High internal moisture contents are generally associated with hospitals, nursing homes, museums, libraries, wet labs or enclosed swimming pool facilities. Portions of buildings containing greenhouses, food processing areas, shower or bathing facilities, computer centers or printing/copying areas also may require localized areas of high moisture levels. Measured air movement through an exterior wall system in our area yielded some astonishing results. The temperature, relative humidity and pressure differentials between the inside and outside of a hospital during the wintertime were instrumented. The amount of moisture passing through one square unit of foil-backed gypsum board was determined. When the foil backing from that one square unit was removed, the moisture passing through by vapor diffusion increased by a factor of 15 to 500, depending upon the type and number of paint coats applied. When the gypsum board, paper facing and applied paint were removed from that same one square unit, the moisture now passing through by air leakage increased by a factor of 5,000,000 over what originally passed through by vapor diffusion. This equates to 40 gallons of water transmitted by air leakage for every drop of water diffusing a given unit area over time. Our Canadian neighbors determined that openings of one square inch around an electrical outlet in the exterior wall, as an example, would contribute nearly 4 gallons of water per month into the exterior wall system. An air barrier must be impermeable, continuous, durable and secured to be capable of resisting the anticipated air pressure differential between inside and outside on a long term basis. In practical terms, both a durable air barrier and vapor retarder are needed in the exterior walls of northern climates. In some cases, these elements may be one and the same, and generally should be located at or inside of the insulation used in the exterior wall. Considerably more moisture, obviously, is transported by convection than by diffusion.

It is not the typical square foot of any exterior wall system that generally creates problems, but rather openings and terminations. In order to avoid potential moisture related problems, it is critical that the air barrier be made continuous at the perimeter, around all openings, and at all penetrations into the exterior wall system, with all joints in the barrier completely sealed. Treatment of the exterior wall above the ceiling, as an example, may provide success or spell disaster.

The combination of concrete masonry back-up, a cementitious parging and closed-cell, rigid insulation is intended to provide the primary air/vapor barrier for the typical exterior wall. Because the surface of the porous concrete masonry units facing the cavity is rarely a smooth plane, parging is utilized to prevent air movement into or between the insulation and the block. Parging is to be applied to the concrete masonry back-up wythe in one coat, with the rigid insulation shoved into the parging while it is still plastic. The insulation is to have intimate contact with the parging and be held there with mechanical means such as

plastic clips frequently spaced. The insulation initially protects the fresh parging and allows it to properly cure, as well as later providing more significant benefits previously mentioned. Without such combination, individual components are of questionable long term performance.

In lieu of a cementitious parging, a modified asphaltic material has sometimes been proposed as the primary component of the needed air barrier. Surface preparation, material, application, coverage, protection and inspection need to be detailed in the bidding documents or associated change documents. Fiber glass is not an air barrier, but may be utilized as a backing for a foamed in place air barrier when so utilized.

When warm moisture-laden air from the inside of the building escapes into an exterior wall system, condensation or hoarfrost build-up may result in related moisture problems. Highly-touted corrosion is only one of many concerns. Degradation of other materials within the wall system or even more visually apparent spalling of facing materials may result. Unsightly efflorescence, wetting of interior finish materials, or even mold or mildew in or adjacent to the exterior wall may also occur.

f. **Rigid polystyrene insulation (extruded preferred) in portion of cavity:** A closed-cell, extruded polystyrene or polyisocyanurate rigid insulation with a minimum two pound per cubic foot density will provide the desired vapor retarder and should be tenaciously secured to the cavity side of the concrete masonry back-up in order for the insulation to satisfactorily perform its entire intended function. The insulation should extend down to the brick ledge, with the upper limit a termination at the support for the parapet. Typically, a 1 1/2" or 2" thickness of insulation is used. Do not require or allow perlite, vermiculite or expanded polystyrene to be placed in the cores of a concrete masonry back-up or in the wall cavity itself. Insulation filling the wall cavity may negate a rain screen design. Insulation in the cores of concrete masonry units may be difficult or impossible to place and may disturb the thermal and moisture stability of that back-up system. Insulation that becomes wet may be rendered permanently ineffective. Saturated insulation can perpetuate high moisture conditions that may be destructive to masonry and metals, as well as interior finishes. Freeze-thaw cycles with saturated, ineffective insulation may allow destruction of the entire facing wythe. Where deemed necessary, increase the thickness of rigid insulation affixed to the cavity side of the back-up wythe, in lieu of providing insulation in other locations.

The location of insulation in the building envelope can either be a benefit or a detriment to long term performance of the building envelope itself. Insulation should be located in the wall cavity as previously indicated, not on the inside of the exterior wall system. This latter position would allow greater thermal movement of the back-up wythe and subsequent disruption, as well as create a potential for condensation occurring anywhere within the exterior wall system. Potential freeze thaw deterioration for portions of the exterior envelope also then exist, especially with the elimination of an unfrozen surface to which moisture can no longer migrate and evaporate.

Another desired feature of the rigid insulation is that it has the capability to bond well with the parging in the cavity to help achieve the air seal desired. Serious consideration should thus be given to requiring a manufactured product with a rough surface in lieu of the typical smooth skin produced. An alternative is to require scarifying the surface of the insulation, such as by wire brush. Use of a modifier to the

mortar in an attempt to improve bond is not a practical solution since its compatibility with the facing material and ease of clean-up are typically not known. A modified parging mortar would also require the use of more than one mortar type in the typical exterior wall system, which generally is impractical.

## 2. DESIGN DETAILS TO BE PROVIDED WHEN APPLICABLE:

a. **Adequate movement joints in masonry.** (See “GUIDELINES FOR MOVEMENT JOINTS IN EXTERIOR WALLS OF NEW BUILDINGS,” Pages III. 1-22.) The plans and specifications as they relate to movement joints must be complete, coordinated, complimentary, and not in conflict. It is highly desirable to show locations and details of each of the different types of movement joints required for a project. There is a need for graphic description of typical vertical movement joints in the exterior facing wythe, concrete masonry back-up wythe and typical horizontal movement joints at the foundation, intermediate shelf angles and the roof. Detail special conditions at corners, in the parapet, between dissimilar materials and elsewhere as needed. Avoid directly through-the-wall movement joints in typical exterior walls. Movement joints in parapets at corners need to be looked at closely. Major “building expansion joints” in new construction as well as major “isolation joints” at junctures of new to existing construction are not included in the guide, but should also be detailed on the drawings.

b. **Base support of exterior masonry wythe on foundation wall ledge:** Provide a desirable “brick ledge” in the foundation at the base of typical exterior walls whenever possible, stepped where necessary and kept above grade. This should be accomplished without a horizontal cold joint in the concrete foundation at the base of the ledge. The height of the ledge should be at least as much as the height of a typical facing unit being used (2 1/4" minimum) and the depth of the ledge should be sufficient to accommodate a facing unit, the cavity and the insulation, back to the cavity face of the concrete masonry back-up wythe. (See drawings titled “Typical Foundation Ledge Detail,” Pages XVII. 9-10.) Such a wall support best turns out any water penetrating the exterior wall system and thus prevents water entering the basement at the top of the wall. It may also eliminate the need for expensive flashing at that location, although a minimal bond breaker directly on the top of the ledge will still be needed. A bond breaker can simply be a 15# roofing felt. Support on the foundation also eliminates the concern for long-term deflection of structural members or corrosion of metal supports if they provide the base for an exterior wall system. Use of a ledge also greatly reduces the potential for deterioration of the facing wythe at grade level. In the event a substantial structural design conflict develops at columns, a masonry soap at such locations should be considered.

c. **Masonry starting above grade:** Masonry facing below grade may deteriorate prematurely. There is no need to promote rising damp with related staining and then put the exterior masonry wythe to the test by subjecting it to the extreme condition of freezing and thawing when saturated. No masonry facing should extend below grade except for temporary work. Appearance concerns will not supercede this requirement. In the event of irregularities in construction or changes in grade, use concrete brick on the foundation wall brick ledge as a filler below grade, rather than clay brick.

- 1. BRICK
- 2. CMU
- 3. CONTINUOUS WALL TIE
- 4. 3/8" PARGING
- 5. 2" RIGID INSULATION
- 6. CONCRETE SLAB
- 7. CONCRETE FOUNDATION
- 8. 2" AIR CAVITY
- 9. PLASTIC DISK WEDGE
- 10. 1" DEEP CONTINUOUS NOTCH
- 11. BOND BREAKER
- 12. WEEP/VENT OPENING

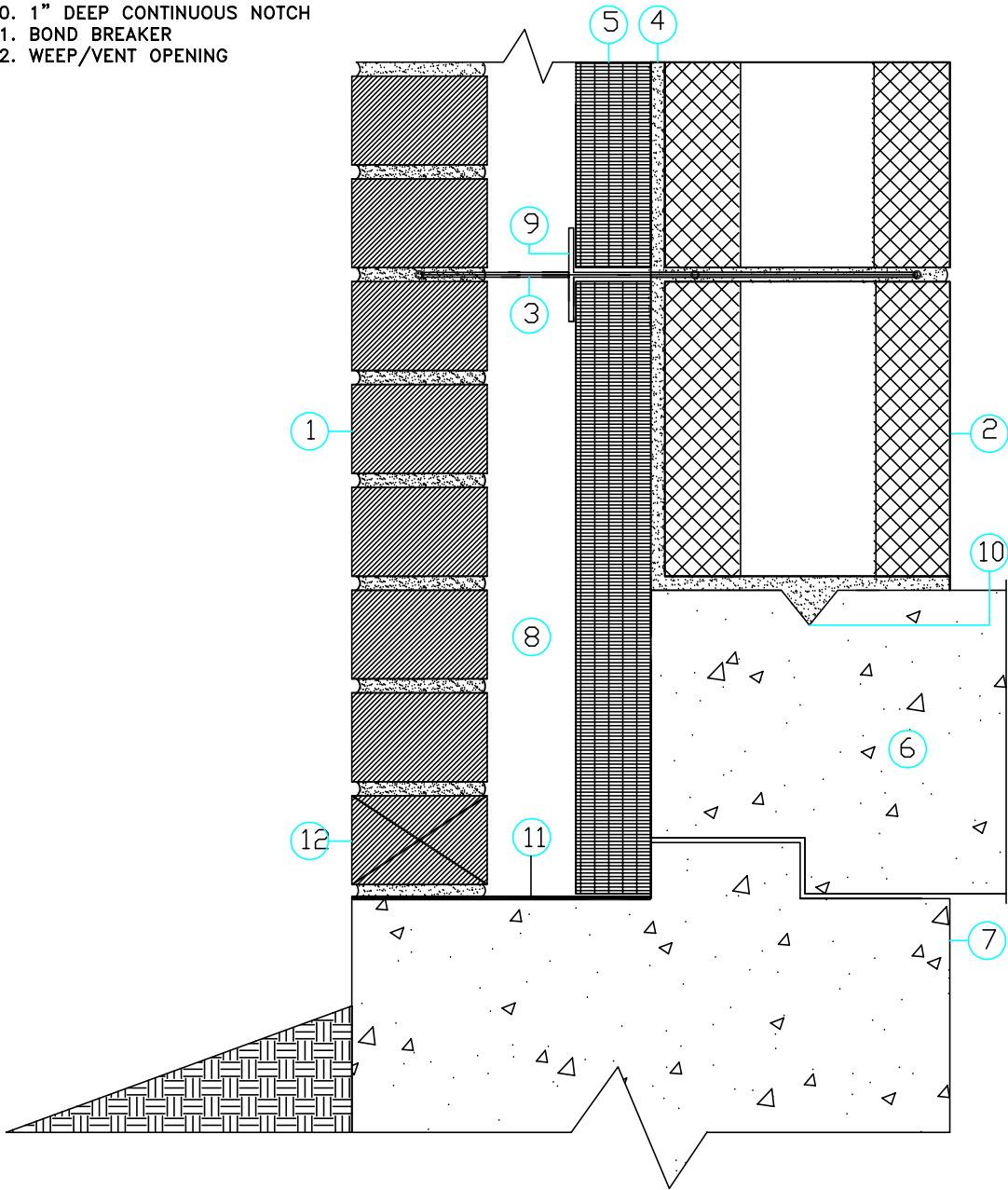

TYPICAL FOUNDATION LEDGE DETAIL (OPTION A)

1. BRICK
2. CMU
3. CONTINUOUS WALL TIE
4. 3/8" PARGING
5. 2" RIGID INSULATION
6. CONCRETE SLAB
7. CONCRETE FOUNDATION
8. 2" AIR CAVITY
9. PLASTIC DISK WEDGE
10. 1" DEEP CONTINUOUS NOTCH
11. FLASHING
12. WEEP/VENT OPENING

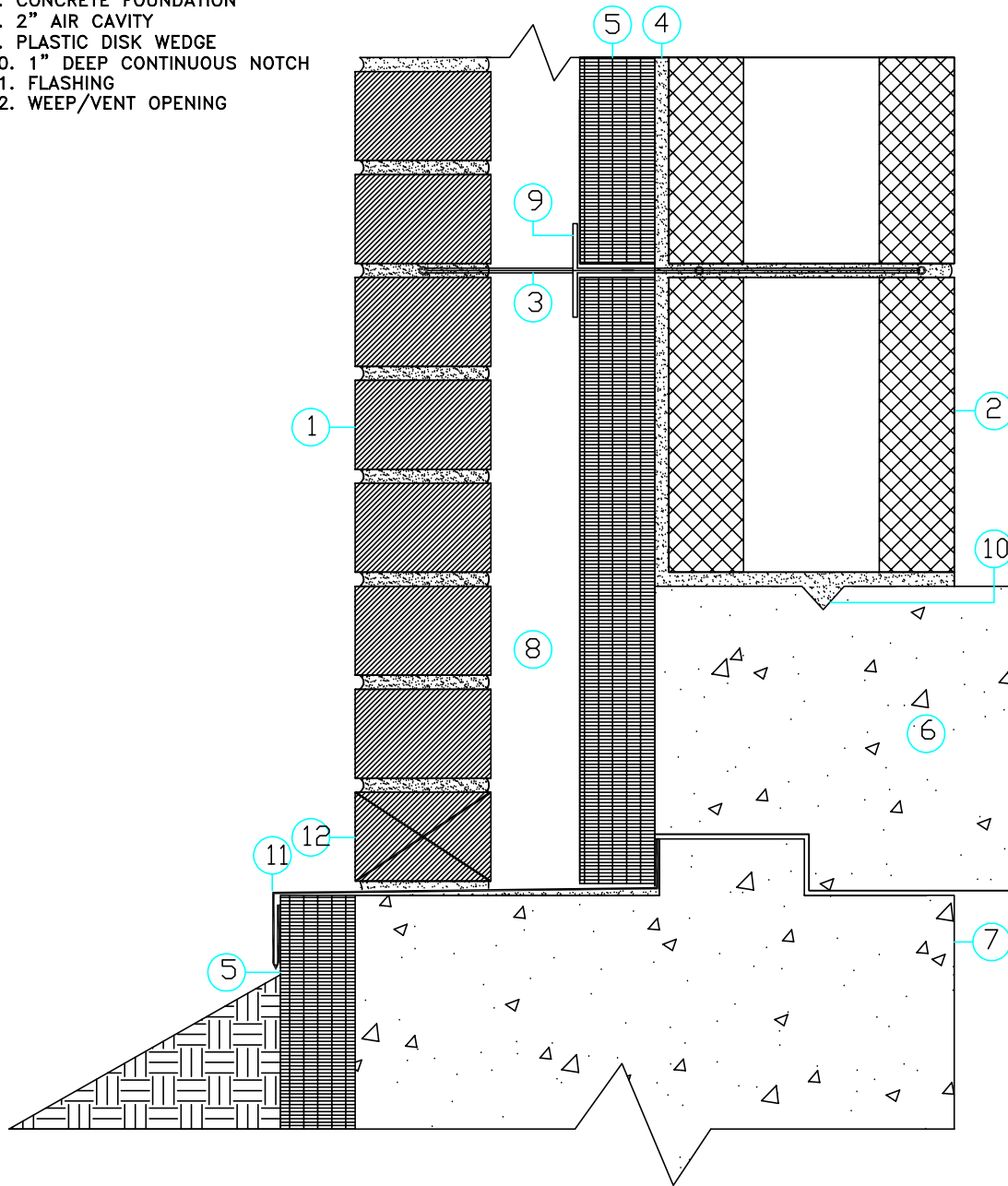

TYPICAL FOUNDATION LEDGE DETAIL (OPTION B)



Unless the concrete foundation is elevated above the grade floor level, earth berms directly adjacent to exterior walls are not recommended because of the increased likelihood of moisture related problems including water penetration, high humidity and excessive dampness. Such problems negate any potential energy conservation benefits that the berms were likely intended to provide. If concealment of something is intended by use of the berm, consider shrubbery or other alternatives instead. It will both be less costly as well as avoid future potential problems.

d. **Mortar-free, open head joints at masonry weight supports on 24" centers max. (32" centers max. when 16" long units are utilized):** The primary purpose of such an item is to ensure that the air cavity is adequately vented in accordance with the rain screen principle. A secondary purpose in some cases is to allow for the escape of moisture from the cavity, both directly and in currents of air. Open head joints should typically be located top and bottom at all floor levels (both directly above and below shelf angles). They should also be located at the heads of openings, and directly above wherever else flashing typically occurs. The open head joints at the top of a wall portion should have the top of the open head joint with mortar sloped slightly down from inside to outside to prevent runoff water draining into the wall. Close-to-ground and other potentially critical areas could be covered with stainless steel screening or stuffed with coarse stainless steel wool to prevent insect manifestations, where such concern exists. Stainless steel material is needed to avoid rust staining. Where insects are a substantial concern, conventional weephole ventilators (grille) of nonstaining metal or ultraviolet resistant plastic composition such as a polypropylene co-polymer may be used, at each head joint. In correctional facilities, open head joints may need to be filled with a drainage mat fabric wherever such joints are readily accessible to inmates. The height of some masonry units may not be compatible with devices that are readily available. An alternate may be the use of a cellular vent (honeycomb) type ventilator, at each head joint. All devices are usually set flush with the face of the exterior masonry. Wick cords, small holes or similar items are not adequate to vent the exterior wall cavity. Consideration should be given to vents located close to grade which may become ineffective in the winter due to drifting snow. Where single story exterior wall systems are unusually high (i.e., physical education building gym walls), additional closures at intermediate heights may be needed for compartmentalization to prevent vertical air movement. In the event same is provided, openings should be provided directly above and below the closure to adequately vent the cavity. An alternate may be a reduction in spacing of the openings or even the use of larger, brick size vents could be considered.

e. **Half-round tubes at counterflashing receivers on 24" centers max.:** Install half-round tubes with edges down and tube sloped out and down. The purpose of such devices is to provide assurance of allowing only air in, but allowing either air or water to exit the wall system, without the need to build up a head of water the thickness of the tube wall in order for water to escape from within the wall. So long as the half-round tube is properly installed and held slightly off the face of the masonry ( $1/2" \pm$ ), water should not enter the half-round tube, even under the most extreme weather conditions. Materials used should be ultraviolet resistant to avoid deterioration. With the 24" spacing indicated, the wall should be well vented at the top to ensure equalized air pressure within the wall cavity. (See drawing titled "Drainage at Counterflashing Receiver," Page XVII.12.)

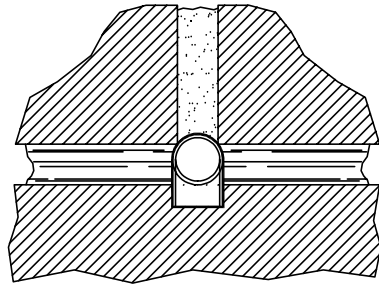

ELEVATION AT WEEP - VENT

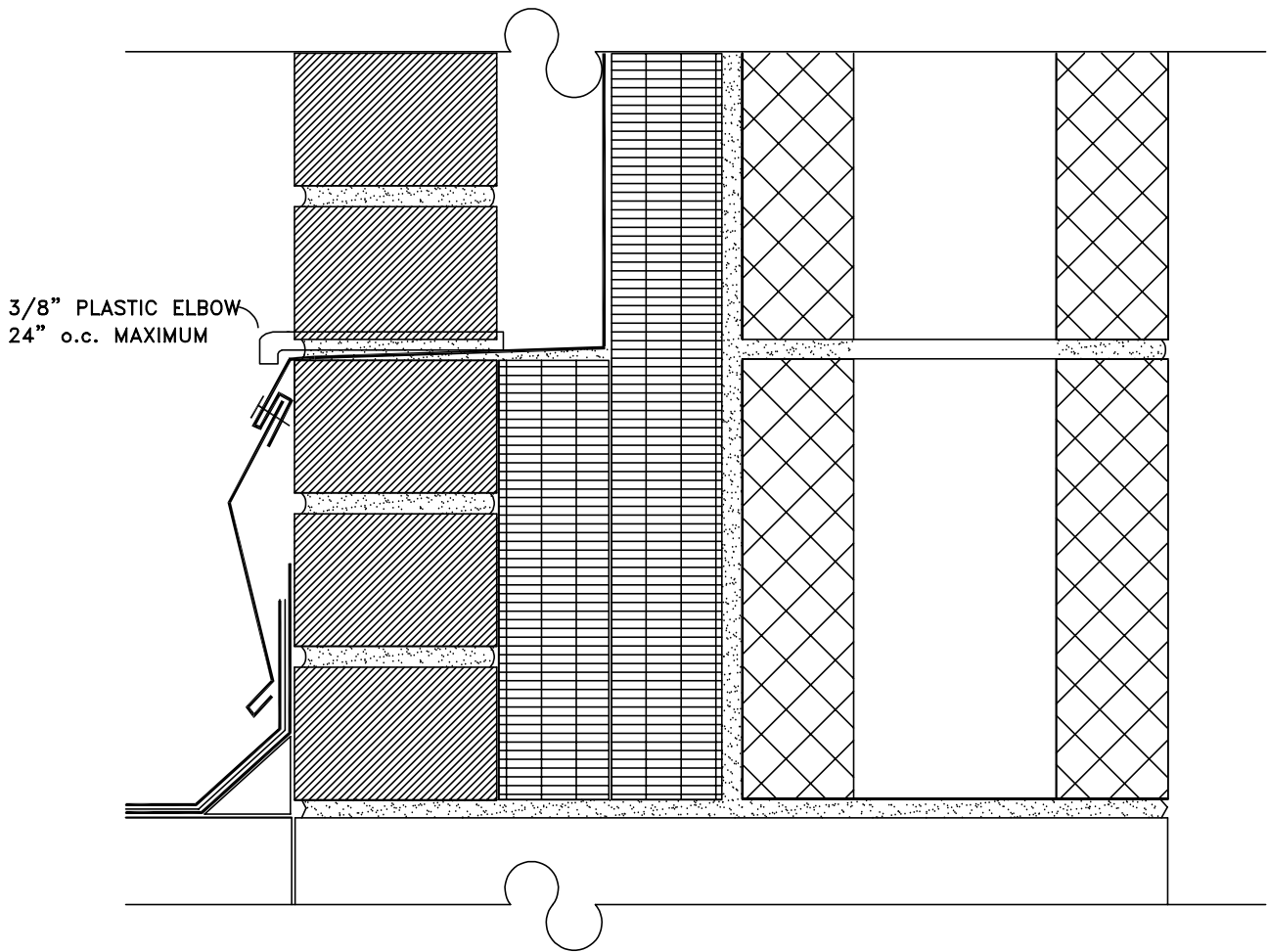

TUBULAR DRAINAGE ELBOW AT COUNTERFLASHING RECEIVER

f. **Positive lateral support for masonry elements at the top and bottom, and sides when feasible:** Such a requirement is primarily to avoid masonry panels tipping out at the top, as has been associated when only wedging of panels at the top has been done. This is associated with masonry growth and frame movements, especially roof slabs and exposed columns. Such type problems have been exaggerated with vertical strip windows adjacent to both sides of columns. There are numerous means to overcome such problems and achieve the ultimate objective. A roughened concrete surface, notch in concrete or dowels are frequently used to laterally support the base of the back-up wythe. Ties into dovetail anchor slots are quite common for lateral support of the back-up wythe, both top and sides, at a spacing of 32" and 16" respectively. Ties at the top of the back-up wythe should be located at head joints filled with mortar. The use of intermittent channels, double or single clip angles are more common at the top of the back-up wythe, with a typical spacing of approximately four feet. (See drawing titled "Block/Spandrel Connection Options," Page XVII. 14.) Method and ease of installation obviously will vary for each option depicted.

g. **Positive air seal at juncture of masonry back-up with underside of roof system, and the wall cavity sealed off at all masonry openings:** Air leakage control is very complex. Air infiltration/exfiltration in buildings is perhaps the least understood failure of the building envelope, and is rapidly approaching a critical concern in northern climates. It is necessary that an air barrier be provided at appropriate locations in order to prevent the flow of air from inside to outside through the envelope and vice versa, and thus avoid free air movement and condensation from occurring. In some situations, a flexible, membrane air barrier may be needed. Types and effectiveness of air and vapor barriers/retarders vary appreciably. They are on occasion one and the same. In nearly all cases the major concern with their effectiveness is at the perimeter as well as openings within the wall system. Infrared scans of buildings for heat loss have been used to confirm excessive air leakage. Sealant materials deteriorate with time and are often are not readily accessible for repair. Fiberglass works well in a furnace filter, but fiberglass is not a material to be used as an air barrier or vapor retarder. Something more positive is needed, particularly at the very vulnerable juncture of wall and roof. Special details will need to be worked out for where the concrete masonry back-up wythe junctures with a sloped roof, fluted metal deck, or where similar complications exist. Special closure pieces exist for some of these conditions. In some cases, flexible, reinforced fabric materials are needed. There is some difficulty in achieving an adequate air seal when the frame of the building is composed of structural steel. Especially vulnerable is the juncture of the concrete masonry back-up wythe with the steel columns. Potential materials and their application need to be well thought out for this condition also. Openings in the masonry wall system for windows, as an example, should provide for the wall opening to be closed off independently of the window itself, both to initially and permanently close off the wall opening. This then allows for window replacement in the future without need for exotic gymnastics in accomplishment of a new air seal. A masonry return at the jamb of a window with a minor thickness of closed cell insulation to prevent direct thermal conduction is commonly used. The heads are typically sealed automatically by the lintel used. The wall cavity at the sill of an opening is generally closed off utilizing closed cell rigid insulation and sealant. A similar arrangement is to be utilized for compartmentalization of the exterior wall cavity at or near corners, as well as intermittently.

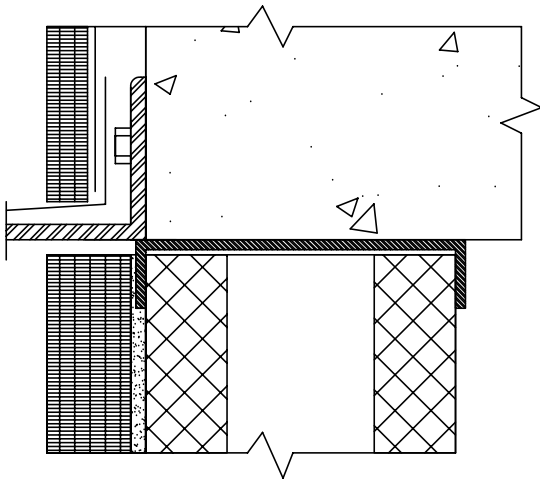

OPTION 1

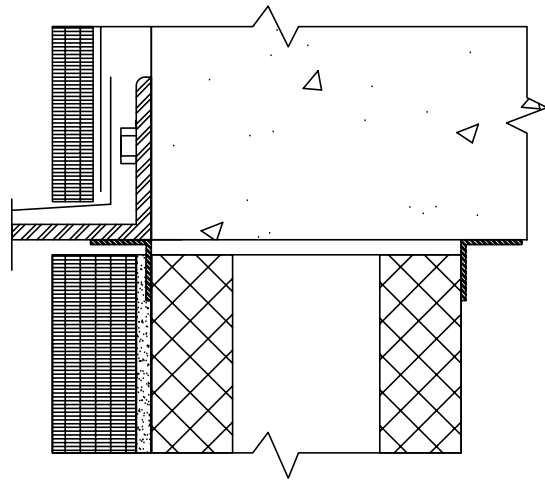

OPTION 2

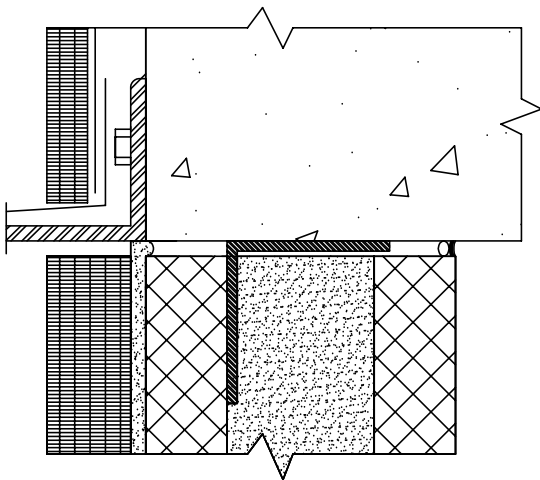

OPTION 3

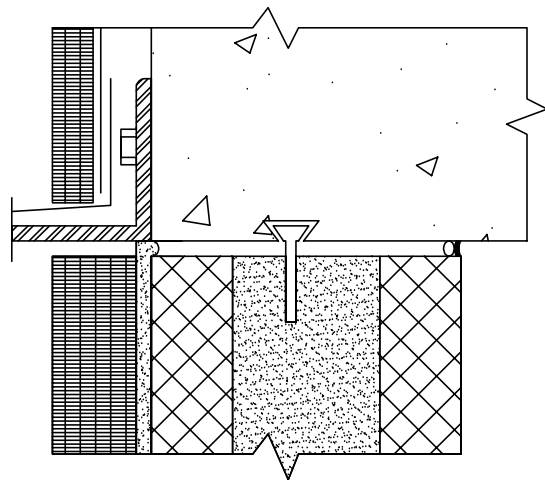

OPTION 4

BLOCK/SPANDREL CONNECTION OPTIONS

h. **Positive fastening of rigid insulation to masonry back-up in cavity by mechanical and adhesive means to insure insulation is permanently secured:** It is essential that the insulation placed within the wall cavity continue to perform its design function. This requires that the insulation retain its proper position within the wall for the life of the facility. To accomplish this objective, dependency on just the presence of metal ties and/or the wet mortar adhesive (parging) used is not sufficient. Methods should be outlined to ensure insulation is mechanically and adhesively secured to the back-up system on a long term basis. The use of plastic disk clips spaced approximately 24" on center at each horizontal joint in the insulation will be needed. The disk clips will function with truss-type continuous joint wall reinforcing, even though the disks have an oblique contact and do not put uniform pressure on the insulation. In locations where the disk clips cannot be used, 22 gauge corrugated metal ties may be used on the same 24" spacing to hold the insulation in intimate contact with the fresh parging mortar. Also, where the insulation is not pressed into mortar parging while still plastic, all joints in the insulation should be sealed with mastic as well. Where rigid insulation is to be in contact with cast-in-place or precast concrete, an adhesive as recommended by the insulation manufacturer should be used to hold the insulation to the back-up, along with mechanical means to retain the insulation in that position. Use of wedges to hold the insulation in place should not be permitted, because such wedges bridge the cavity.

i. **Back-up masonry and any other air or vapor barrier sealed at perimeter and penetrations with appropriate sealant:** The air/vapor barrier is correctly located at the cavity face of the concrete masonry back-up wythe. Types and effectiveness of air/vapor barriers or retarders vary appreciably. Batt insulation is not an appropriate air barrier. The very important primary air barrier should be clearly identified on the drawings along with detail necessary for its accomplishment at the termination with other construction.

Ensure that all architectural, electrical, plumbing, mechanical, etc., openings/penetrations in the concrete masonry exterior wall back-up wythe are well sealed by the appropriate trade on the cavity side, so that a true, long term air barrier is maintained. The more unusual must also be handled, such as an interior piping chase with large openings in the floor system that partially occur directly beneath the air cavity in the wall, thus being able to compromise design utilizing the rain screen principle.

The method of terminating the air seal in a permanent manner must take into account the magnitude of the pressure differential across the seal, so that the closure is not simply blown out or in. Causes of pressure differentials include mechanical ventilation systems, wind conditions, barometric pressures, and tunnel and stack effects.

j. **Overhangs on copings, caps and sills, with drips and flashing directly below:** Building facades need to be designed to prevent concretated sources of water from reaching the wall. Drips serve a very important function in buildings and will be briefly discussed herein. When a parapet is mandated, for whatever reasons, the first choice detail is typically a stone or concrete coping with projections and drips on both the inboard side as well as the outboard side of the parapet, along with metal flashing beneath the coping. The alternate choice is a prefinished metal cap coming well down over the masonry having functioning drips both sides, along with flexible flashing. Do not use flush coping nor dysfunctional drips, as they do not properly perform, and they do cause problems.

Where stone or concrete coping, caps or sills are utilized, they should project an absolute minimum of 1 1/2" beyond the face of the masonry where exposed, and contain drips on bottom exposed faces with through-wall flashing beneath. The top of the copings or caps should be sloped to both outside and inside, or to the inside only. The tops of sills obviously should drain water away from the wall, not funnel water towards the wall. Where bed joints for multiple elements are on a level surface below them, the elements are to be doweled end-to-end rather than have dowels penetrating down through the flashing into the substrate below. Where dowels are required to penetrate into the bed joint, because of slope or other special conditions, weld/solder sleeves onto the flashing through which the dowels pass. (See drawing titled "Sleeve For Dowel Penetrating Flashing," Page XVII.17.) Operational movement joints are necessary on a frequent basis in the head joints between elements to avoid excessive movement of the elements. Movement joints between stone or concrete coping or cap pieces should always occur in line with movement joints in the parapet or wall below. The metal flashing in the bed joint below the elements should be exposed and possess a drip. The flashing should have a slight crease down its center (like a sloped roof) or have a convex configuration, so water from above does not pond on top of the flashing but is rather directed out to the sides. This will require a partial mortar bed both above and below the flashing. (See drawing titled "Wall Cap Detail," Page XVII. 18.) Ensure that the underside of the flashing at any face of the masonry is fully bedded in mortar or caulked to prevent entry of wind driven rain. In some situations, a caulk bead on the underside of the flashing at the juncture with the brick is mandatory. Do not use any sealant in coping/sill bed joints on top of the flashing. Such action usually creates substantial problems, since any moisture entering the wall system from above thus becomes trapped therein.

The ends of stone or concrete sills should generally extend into the adjacent masonry several inches. This will avoid downward water penetration when sills are just butted against the adjacent masonry and the sealant eventually fails. An alternative may be to pitch both ends of the sills to provide drainage away from the brick jambs.

Where metal elements are utilized as a sill, coping or roof edge, they should terminate in a drip on exposed faces, with flexible flashing beneath. A 40 mil EPDM is an acceptable flexible flashing for such construction. The flexible flashing should be fully and continuously adhered to the entire vertical surface for all those portions of the construction being concealed by the metal. Use cover plates between pieces of metal elements, which is not intended to be watertight but rather to protect the flashing beneath. Show return or closure piece at ends of sills. (See drawing titled "Aluminum Sill Cover," Page XVII. 18 for typical cover utilized in retrofit.) The metal elements should extend over all blocking and at least one nominal brick masonry course and a mortar joint (2 1/2" absolute minimum) wherever exposed. (See drawing titled "Typical Roof Edge Detail (metal cap flashing)," Page XVII. 19.) This is to avoid water being blown up under the coping in all but the extreme of circumstances. Each 10 mile per hour increase of wind velocity will move water up the wall one more inch, reduced by the presence of a drip. Such design also allows elimination of the sealant otherwise needed between metal and masonry, which would periodically require replacement.

Functioning drips interrupt and divert rain water and snow melt runoff over masonry, apertures such as windows and doors, and other construction. Drips thus reduce the amount of water absorbed into the exterior wall system, protect lintels and frames from water penetration and subsequent corrosion and staining, and minimize the amount of water carrying debris which dirties windows and the like. A drip also shields the sealant behind from ultraviolet deterioration.

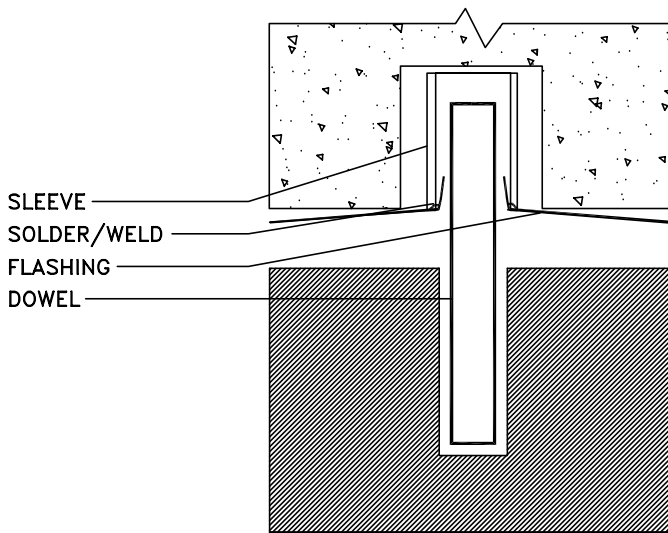
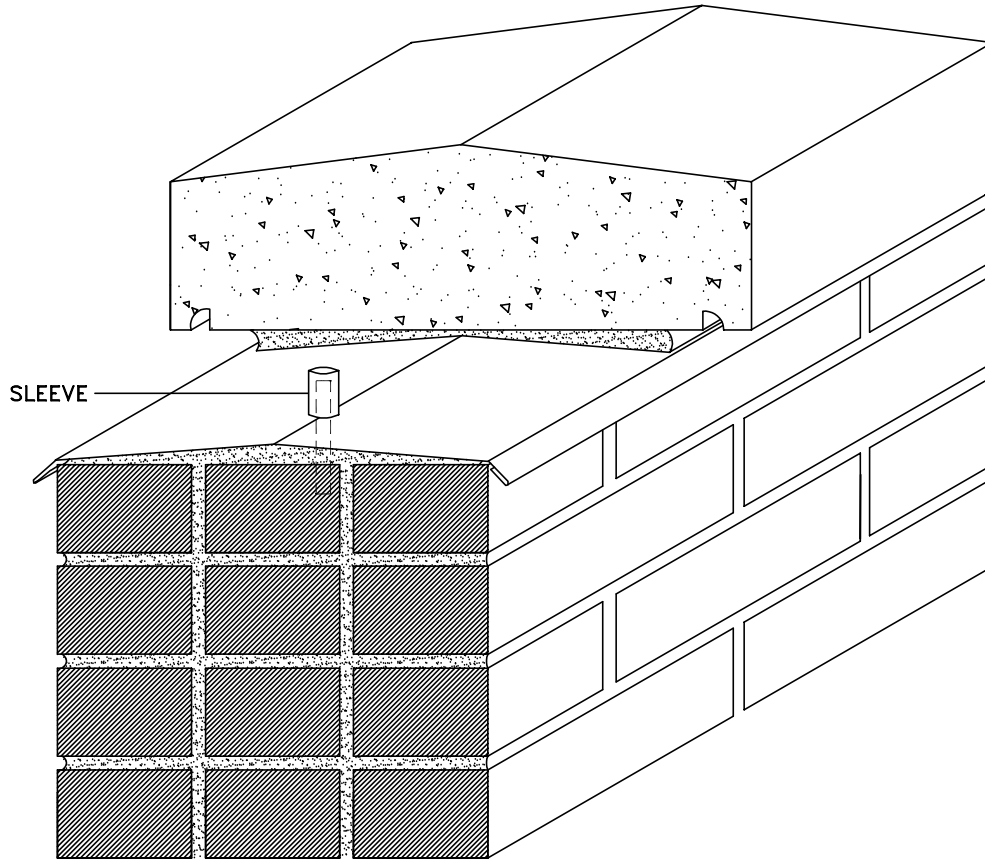

SLEEVE FOR DOWEL PENETRATING FLASHING

1. STONE OR CONCRETE CAP
2. FLASHING SLOPPED AND BEDDED IN MORTAR WITH A 3/4" DRIP
3. DRIP 3/8" WIDE BY 3/4" DEEP
4. 6" REINFORCED CONCRETE
5. 1" AIR SPACE
6. BRICK
7. HOLE AND SS DOWEL

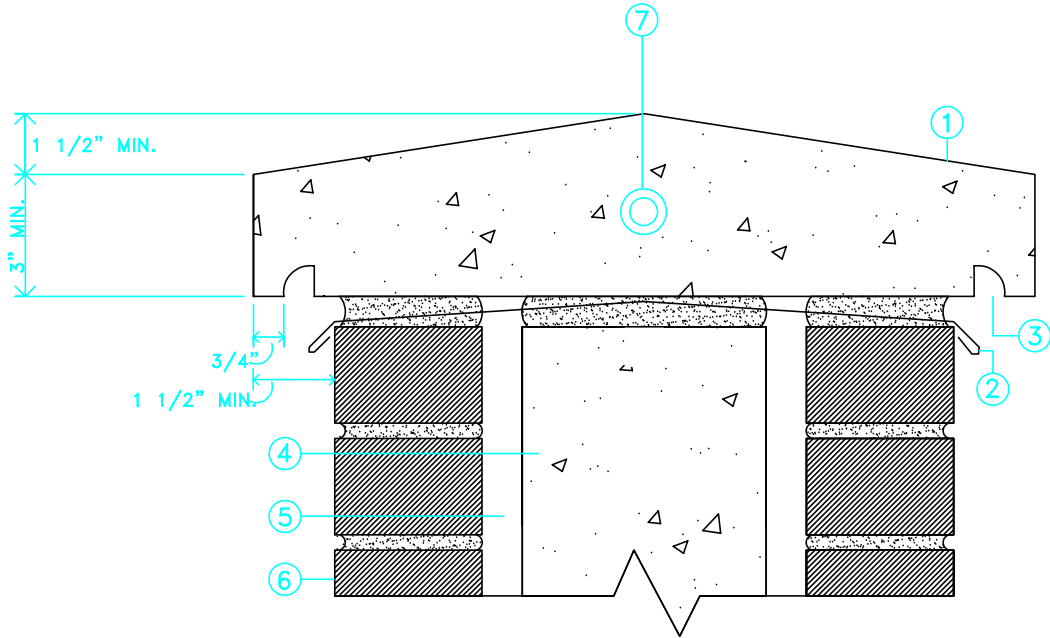

WALL CAP DETAIL



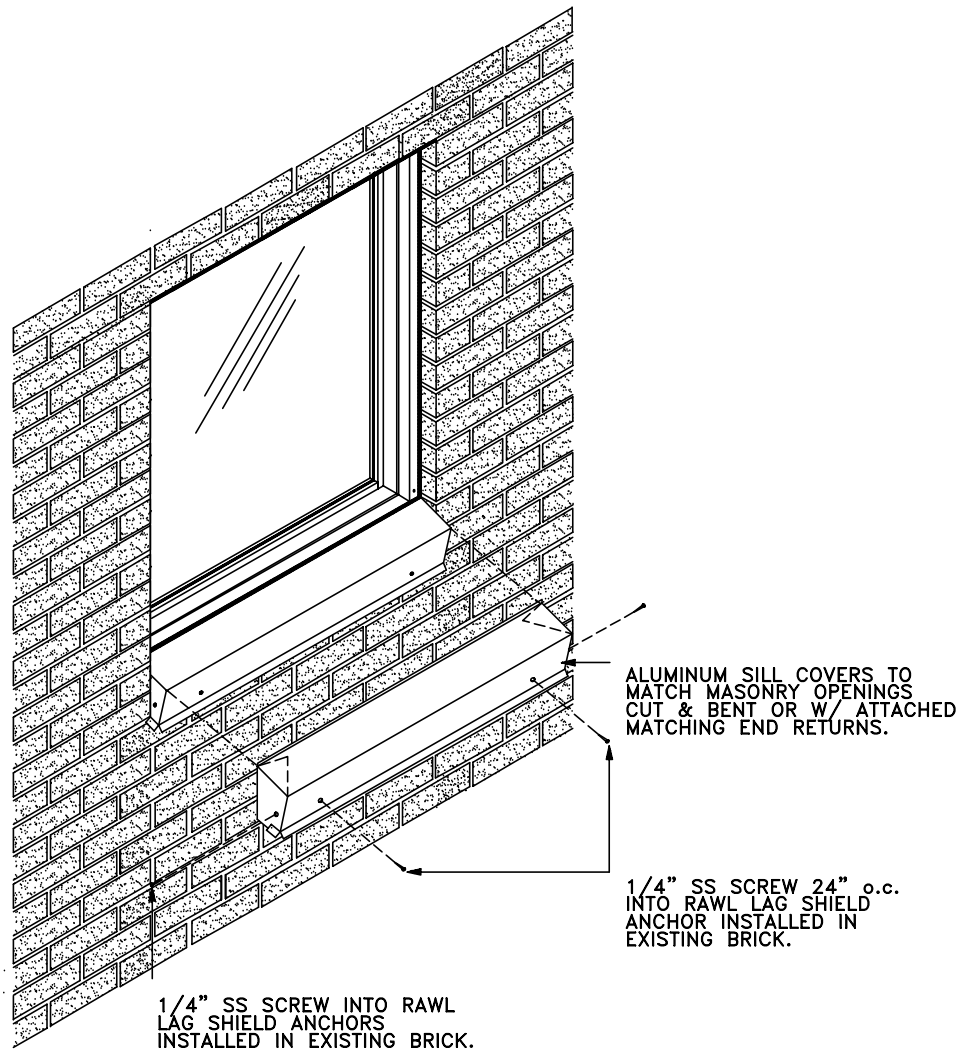

ALUMINUM SILL COVER

1. FLEXIBLE FLASHING  
FULLY ADHERED
2. COPING
3. BEVELED WOOD SIDING
4. TREATED WOOD BLOCK
5. CONTINUOUS CLEAT
6. FASTENER @ 12" o.c.
7. FASTENER THRU NEOPRENE  
BACKED WASHERS @ 2' o.c.  
(coping shall have slotted holes)
8. SEALANT
9. COUNTER FLASHING
10. FLASHING
11. BUILT-UP ROOFING
12. WOOD FIBER CANT
13. MIN. 2" INSULATION
14. SEALANT & BACKER ROD
15. POLYETHELENE PAD
16. 1" RIGID INSULATION
17. 4" x 7" x 3/8" ANGLE
18. ANCHOR
19. DOVETAIL ANCHOR SLOT
20. PLASTIC DISK WEDGE
21. VENT OPENING
22. DOWEL 4'-0" ON CENTER

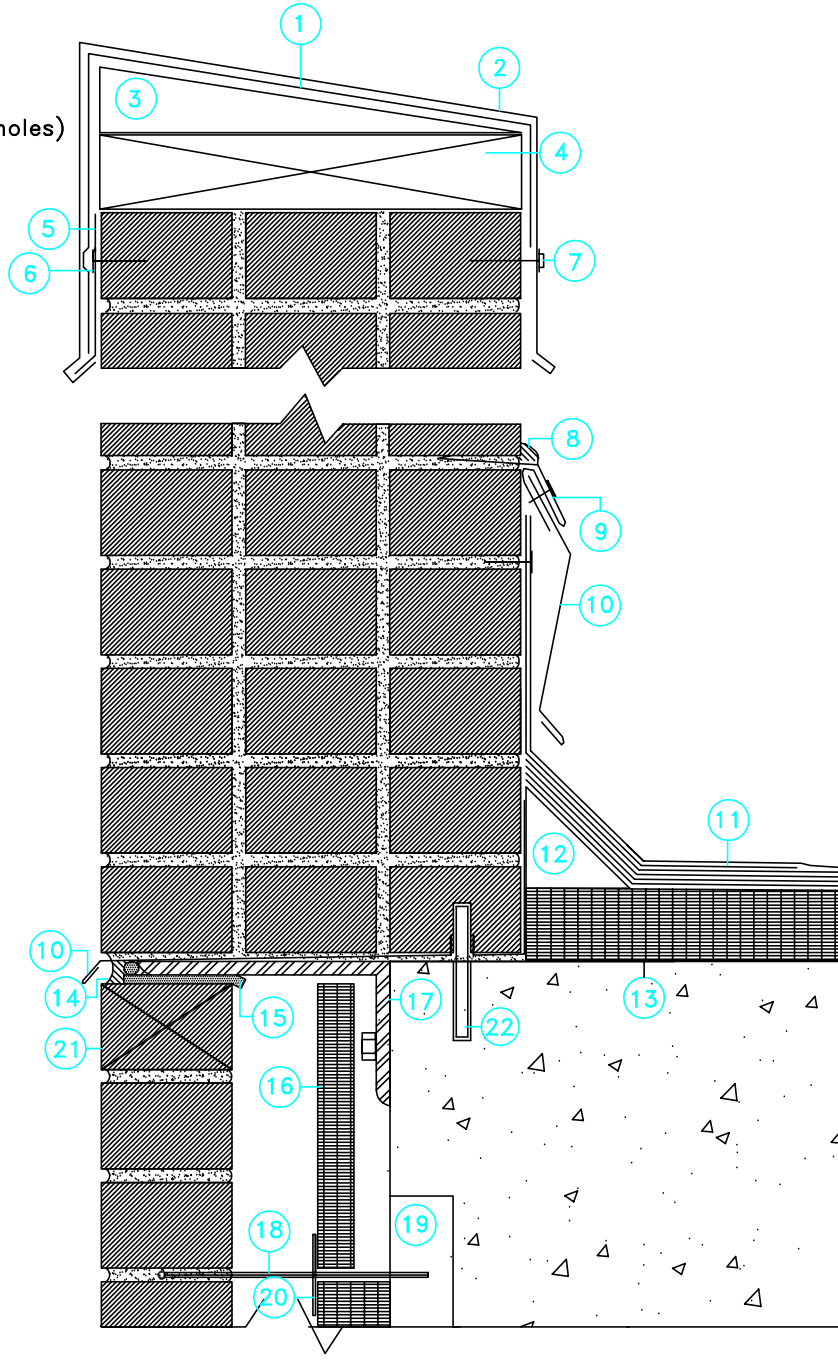

TYPICAL ROOF EDGE DETAIL  
(metal cap flashing)

During the winter, snow and ice build up, primarily on non-vertical surfaces. On a calm, sunny day sufficient heat is generated to melt a portion of the snow or ice. Without a proper drip, this water then penetrates into the exterior wall system, whereupon reaching a cold surface in the shade, the moisture reverts back to a solid state and continues to build up. Subsequent cycles of freezing and thawing can then wreak havoc with a saturated masonry system causing substantial damage. In the event some of the drip portion of the flashing needs to be removed for whatever reason, it is imperative that the flashing project slightly beyond the masonry surface and the raked mortar/opening below the exposed flashing be caulked. This is to prevent runoff from the wall above easily entering the wall at this vulnerable location.

Care must be taken to ensure that water run-off from the roof is not allowed to flow over the surface of the masonry. Effective drips or gutters will be needed.

A drip should be provided at a fascia soffit juncture, with venting of the space above and behind through a moisture insensitive soffit. Ensure the design/construction is such that the bottom of the fascia is built and stays in the same vertical plane with the roof edge, or better yet slightly behind it, to ensure a functioning drip is achieved. If there are no roof drains, scuppers, gutters or downspouts, water drains off the roof edge. If water from the roof edge impinges on the surface of the fascia, the action of droplets upon reaching a conventional drip below is to scatter both outward as well as inward, approximately 45 degrees from the vertical each way, which wets the wall below unless the overhang is great. This can be similar to what occurs below a ruptured gutter/downspout and could saturate the masonry, leading to freeze thaw deterioration.

k. **Corrosion-resistant metal flashings at masonry weight supports and the head and sill of all wall openings, exposed a minimum of 3/4" and turned down to serve as a drip:** (See "GUIDELINES FOR EXTERIOR WALL FLASHING," Pages IV. 1-5.) The primary purpose of flashing is to intercept moisture moving down in the exterior wall system and redirect it to the outside. Flashing must be sufficiently strong to resist tearing in the wind during construction. Flashing life should be compatible with masonry life, as it is very difficult and expensive to replace/provide flashing in existing masonry. Non lead-coated copper and non anodized aluminum flashing could cause staining. The federal Environmental Protection Agency (EPA) is presently considering limitations on use of lead, which may ban some lead-base, coating materials currently being utilized. Laminated flashing has a tendency to split apart where exposed due to bimetallic action when subjected to differential thermal movements. Polyvinyl chloride (PVC) flashing tends to shrink and embrittle with age as it loses its plasticity, in a relatively short number of years. PVC flashing is prone to job site damage such as puncture and abrasion, and is also subject to ultraviolet deterioration where exposed. Therefore, don't use PVC flashing. A modified-bituminous, flashing material with a thin, metal covering and/or exposed metal drip is currently being utilized in some commercial applications. One exception to the general use of stainless steel for flashing is beneath a metal coping. A terpolymer of ethylene propylene and diene monomer (EPDM) flashing fully adhered to the vertical surfaces of the blocking and masonry, fully covered by the metal coping is permissible for this application. Where counterflashing is attached to the through-wall flashing, stainless steel counterflashing should also be considered to preclude electrolytic deterioration due to contact of dissimilar materials. An alternate might be prefinished metal or use of other electrolytic insulators.

Exposed flashing with a drip has its own merits, but also provides opportunity to visually check that flashing is installed, continuous/lapped, and likely functional. "Concealed flashing," through-wall

flashing held back and not brought out to the face of the wall, should be totally banned from construction. Such installation creates problems of breaking bond, and is nearly oblivious to its intended function of turning water out of the wall. There is substantial risk that water from outside or inside the wall may run back under the front edge of the flashing and down into the wall below. Such a condition is usually driven by concerns of initial appearance, but commonly results in long term leakage and efflorescence problems. Avoid through-wall metal flashings exposed both outside and inside because of thermal conduction and potential condensation problems resulting. Proper flashing details at sills may sometimes become very complicated to avoid thermal bridges. (See drawing titled "Typical Sill Detail," Page XVII. 23.)

It is generally preferable to utilize a two-piece flashing in order to accommodate necessary construction tolerances. The top piece should come out of an angled-down reglet in a concrete spandrel or from behind a counterflashing type assembly on a steel beam, and turn vertically down. The lower part of the flashing assembly should be fastened to the back-up at a maximum spacing of 24 inches on center and come up behind the upper flashing portion (shingle fashion), with a minimum overlap of 2 1/4 inches. The flashing should extend down vertically to the top of the shelf angle, and then extend to the surface of the masonry, terminating with an exposed drip which protects the masonry below as well as the sealant behind. In lieu of fastening the lower piece and providing a shingle type overlap between the two flashing pieces, they may juncture in a lock seam. Another alternative is a two piece interlocked flashing with the lower piece slipped into a bend in the upper piece, thus allowing some adjustment. Whatever method is decided upon should be appropriately detailed. (See drawing titled "Flashing Connection at Shelf Angle," Page XVII. 24.) Surface mounted through-wall flashing will not be tolerated.

The flashing should generally be fabricated with slightly more than a 90 degree angle where the flashing changes from near horizontal to near vertical in the wall, to insure positive outflow of any water collected in the wall. This generally means the flashing is laid on a beveled bed of mortar on top of the shelf angle. The same requirements apply where through-wall flashing is utilized as a counter-flashing receiver. The near vertical portion of the flashing is located inside or on the warm side of the wall insulation, which is generally reduced in thickness at the location of the flashing. Flashing that is to terminate in a bed joint of the concrete masonry back-up wythe should have a minimum height of 2 1/4 inches above the level where the flashing is exposed, penetrate into the back-up wythe at least the thickness of the concrete masonry unit face shell, and contain a 1/4 inch minimum back dam. A two piece flashing may be utilized for this condition with a 2 1/4 inch minimum overlap. A combination through-wall flashing and counterflashing receiver is generally preferred over two separate elements, in order to avoid breaking bond in two different bed joints that are in close proximity to each other.

1. BRICK
2. STONE SILL
3. FLASHING
4. 1" INSULATION
5. 2" INSULATION
6. 2" AIR CAVITY
7. CMU
8. CONTINUOUS WALL TIE
9. PLASTIC DISK WEDGE
10. 3/8" PARGING
11. VENT OPENING
12. MESH TO SUPPORT MORTAR

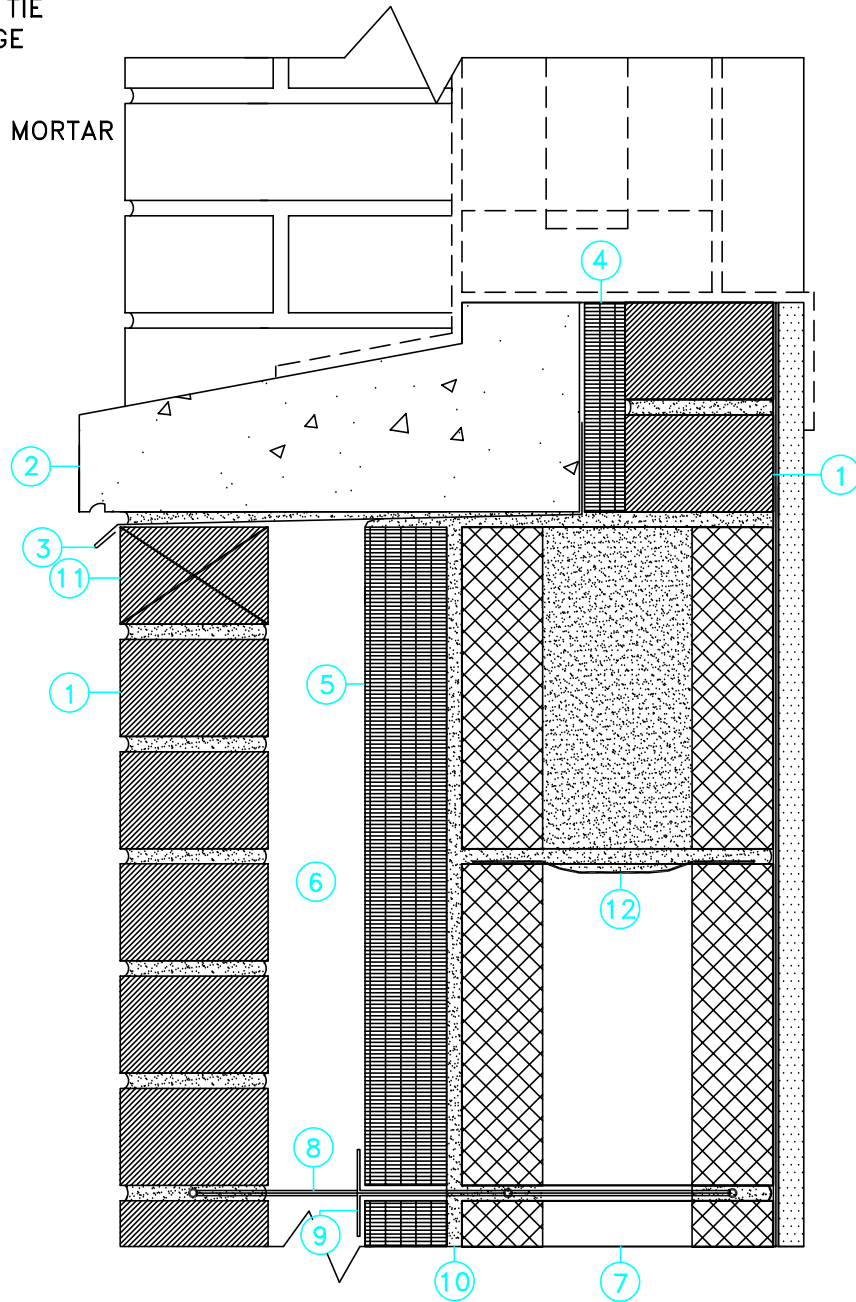

TYPICAL SILL DETAIL

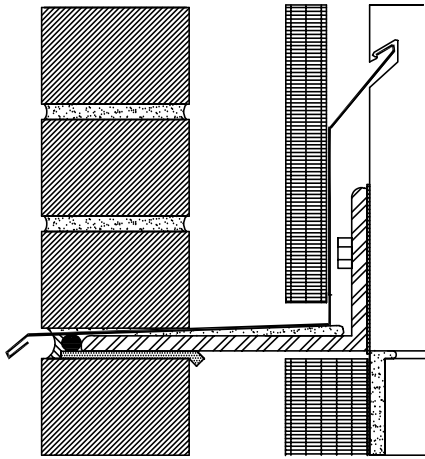

OPTION 1

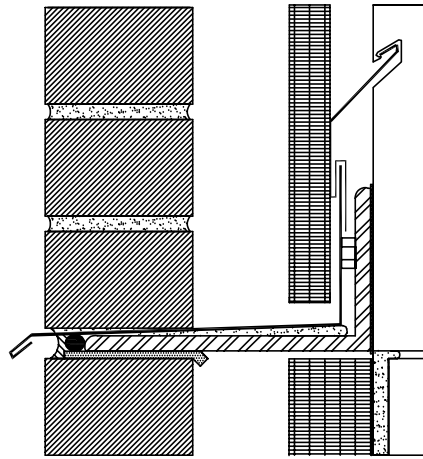

OPTION 2

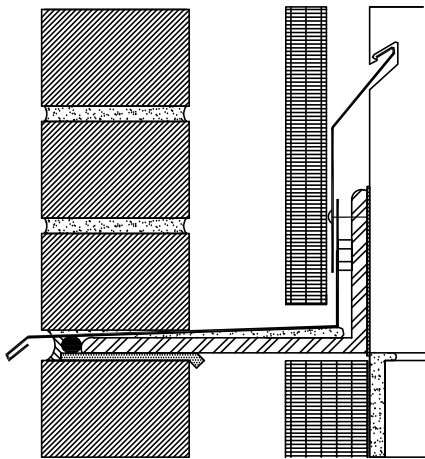

OPTION 3

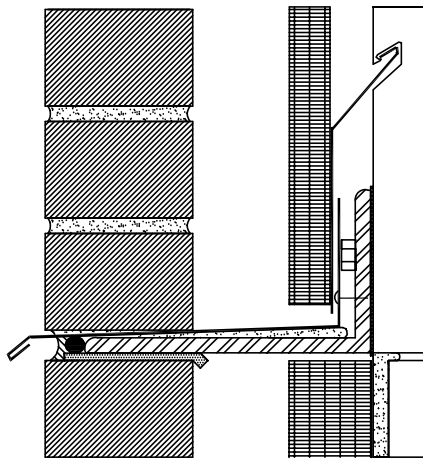

OPTION 4

FLASHING CONNECTION AT SHELF ANGLE

If through-wall flashing is back-sloped, this condition funnels exterior water into the wall, which would otherwise never enter the wall, at weep holes, or at bed joints between flashing and the masonry above. With this reverse slope, the flashing then does just the opposite of what it is suppose to do, namely discharging water that enters the wall elsewhere or is created by condensation. To avoid water penetration problems when flashing is placed in such a manner, the joints between pieces, end dams, back dams, corners and steps must all be perfectly made and installed to last the life of the flashing. The “horizontal” portion of the flashing must not project as a ledge beyond the face of the masonry, which would otherwise aggravate the situation by diverting and dumping more water into the wall. (See drawing titled “Common Flashing Problems Being Experienced,” Page XVII. 26.) These problems can be fairly easily overcome by periodic checking with a hand level when flashing work is in progress, placing emphasis on early work being done. A thin bed of fresh mortar below the flashing is necessary to ensure proper slope of flashing out and down, as well as to make intimate contact between mortar and flashing to avoid openings which could be a source of entry for wind driven rain.

When a roof system junctures with a wall above, metal through-wall flashing and related details are critical to turn water out rather than allow it to drain down. Fill cavity below through-wall flashing with masonry or rigid insulation to fill the void and to allow continuous support of flashing from beneath. A beveled mortar bed should be applied in this area to cause a down and out slope of the flashing which directs water to the exterior. This minimizes dependence on joints and dams in the flashing. (See drawings titled “Throughwall Flashing Detail Juncture at Low Roof to Wall Above,” Pages XVII. 27-29, and “Throughwall Flashing Problem Juncture at Low Roof to Wall Above,” Page XVII. 30.)

Continuous caulking installed on top of a through-wall flashing at the surface of the exterior masonry will prevent moisture from exiting the exterior wall system at the appropriate location. Moisture may be from rain or snow melt water penetrating the wall above or condensation forming within the wall itself. Such a caulking seal may allow the build-up of a hydrostatic head of water in the exterior wall and redirect water to flow down through irregularities into the masonry below.

Where flashing is required to be stepped, such as in the gable end of a building, a positive seal should be provided between flashing pieces. One end of the lower piece should be turned up with a high end dam to engage the upper piece. One end of the upper piece should be turned down to overlap the lower piece shingle fashion, a minimum of 2 1/4 inches. Seal juncture of end dam with back leg of flashing. An alternative is to provide end dams on both upper and lower pieces and overlap them horizontally a minimum distance of one-half the vertical distance between them. (See drawings titled “Flashing Stepping Down,” Pages XVII. 31-32

It is desirable to show location and details of typical exterior wall flashing required. Special conditions should also be detailed. On some large projects, an actual schedule may also be helpful. Provide hem on edge of all exposed flashing to be located where people contact is likely after construction. Be sure to coordinate flashing installed by Section 4200, Masonry, with flashing provided and fabricated by Section 07620, Sheet Metal Flashing and Trim. When exterior wall flashing (excluding coping, caps and loose lintels) exceeds 1000 lineal feet or the flashing installation is intricate, consideration should be given to requiring that such flashing be installed by the sheet metal fabricator. Responsibility for activities to achieve final completion of sheet metal corner fabrication, or any special installation of flashing in the field, should be clearly outlined in the specifications. It is suggested that this responsibility be totally assigned to Section 07620.

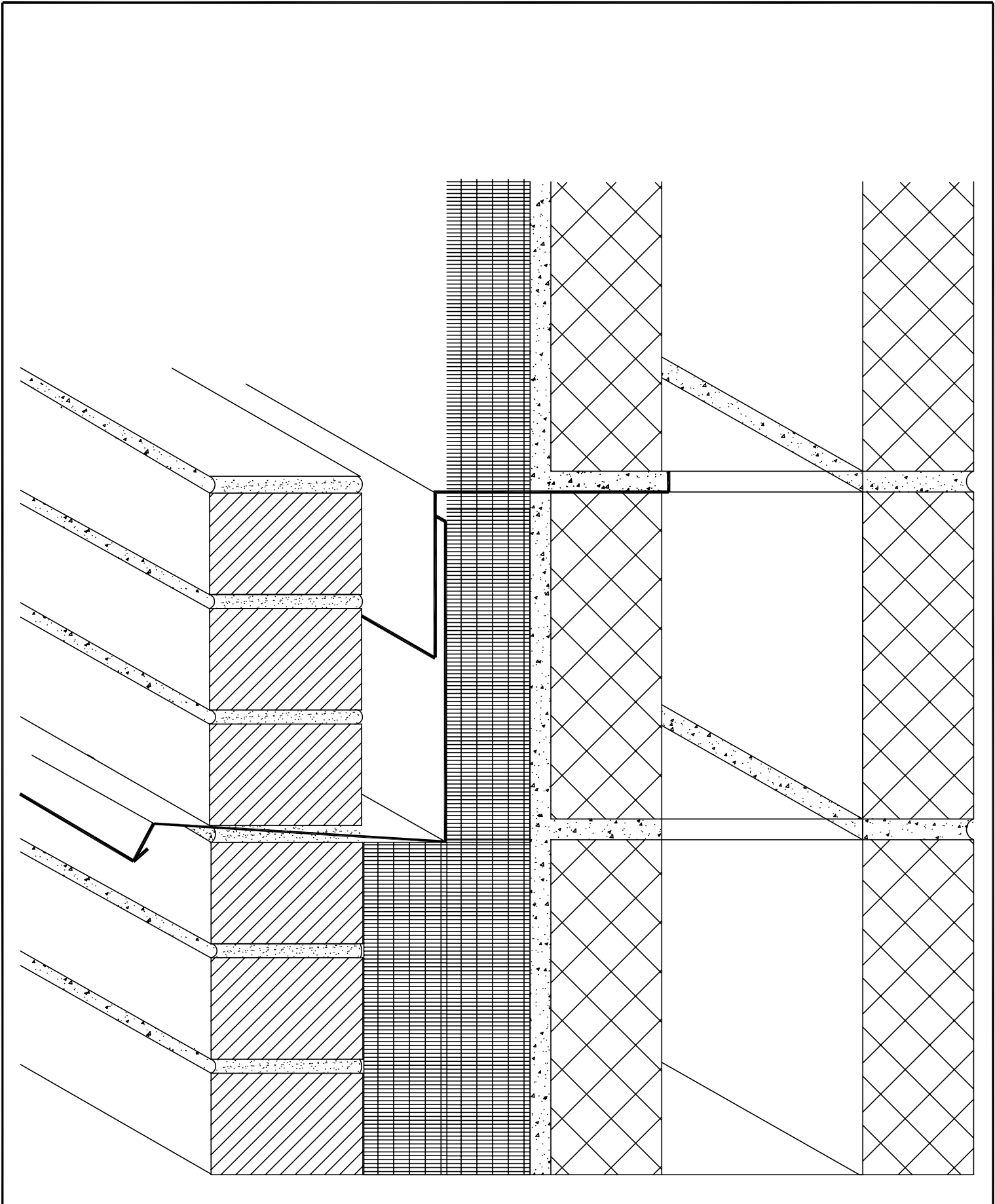

COMMON FLASHING  
PROBLEMS BEING EXPERIENCED



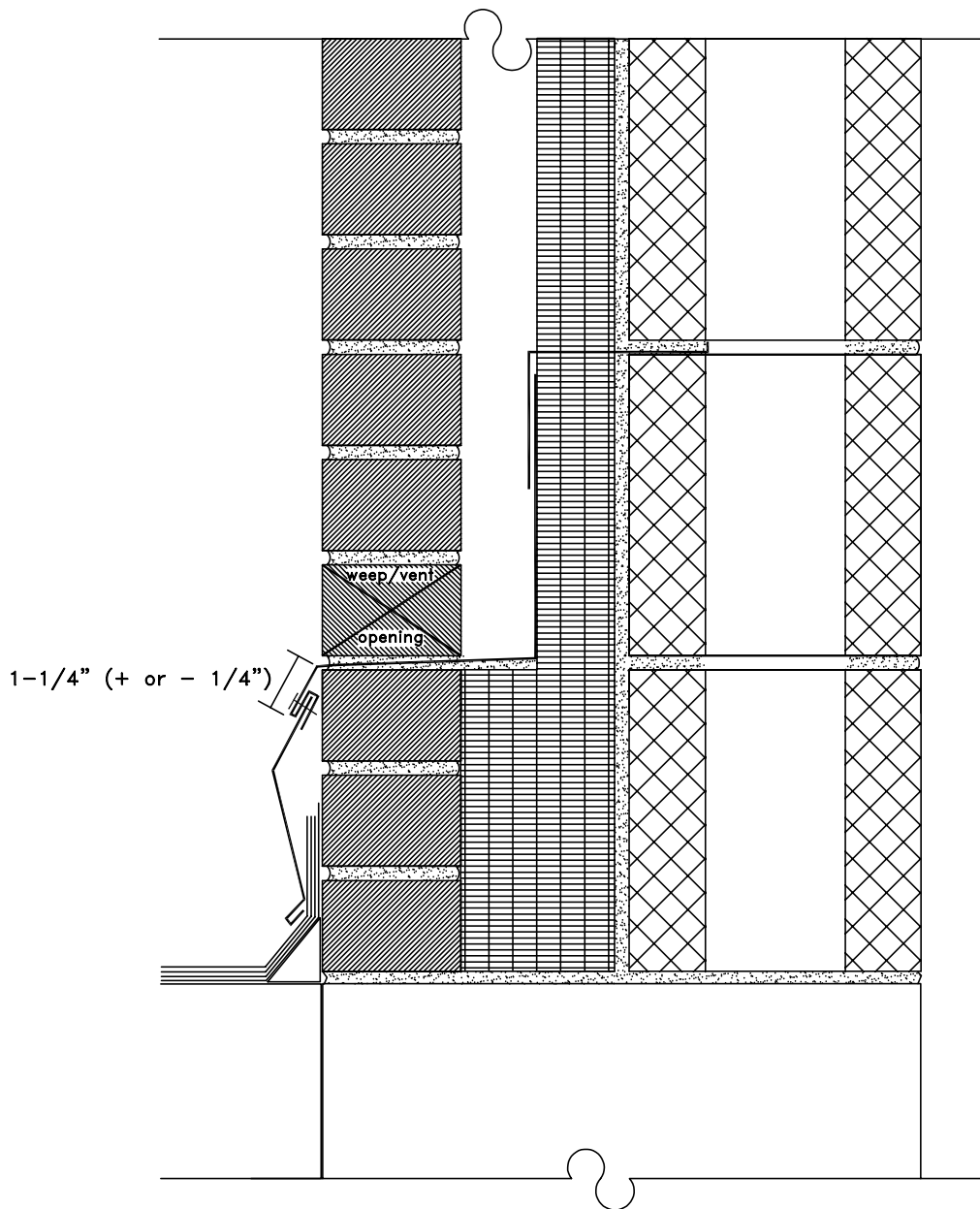

NOTES:  
 LAP (MINIMUM 2") & SEAL ALL JOINTS  
 PROVIDE END DAMS AT INTERRUPTIONS  
 PROVIDE PREFABRICATED PIECES FOR ALL CORNERS

THROUGHWALL FLASHING DETAIL  
 JUNCTURE AT LOW ROOF TO WALL ABOVE

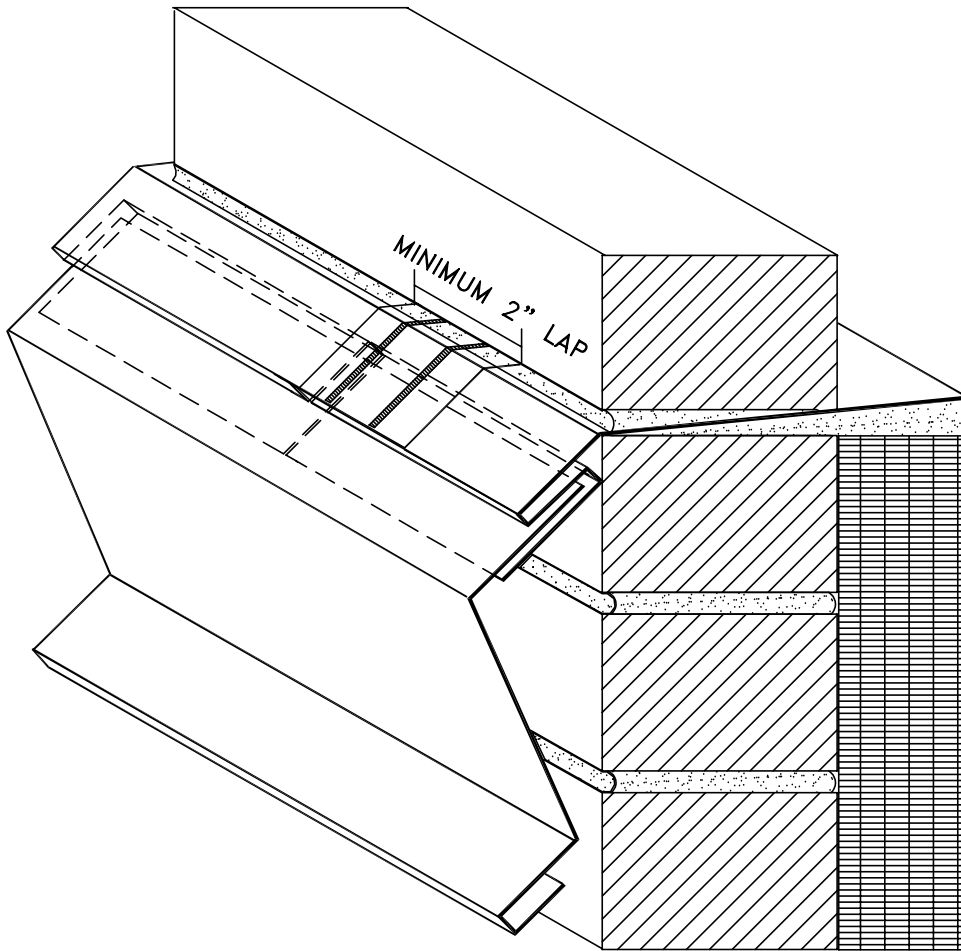

THROUGHWALL FLASHING DETAIL  
JUNCTURE AT LOW ROOF TO WALL ABOVE

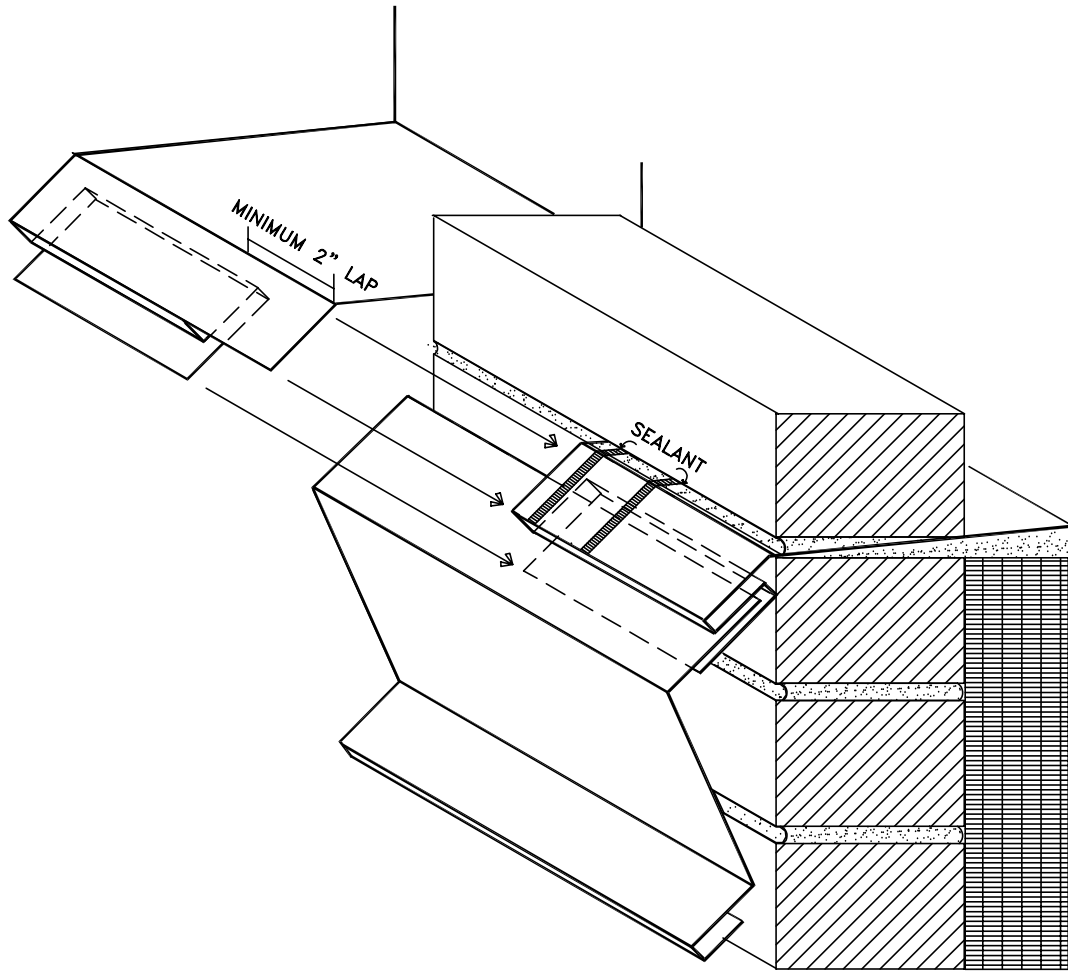

THROUGHWALL FLASHING DETAIL  
JUNCTURE AT LOW ROOF TO WALL ABOVE



REFER PAGE XVII. 29

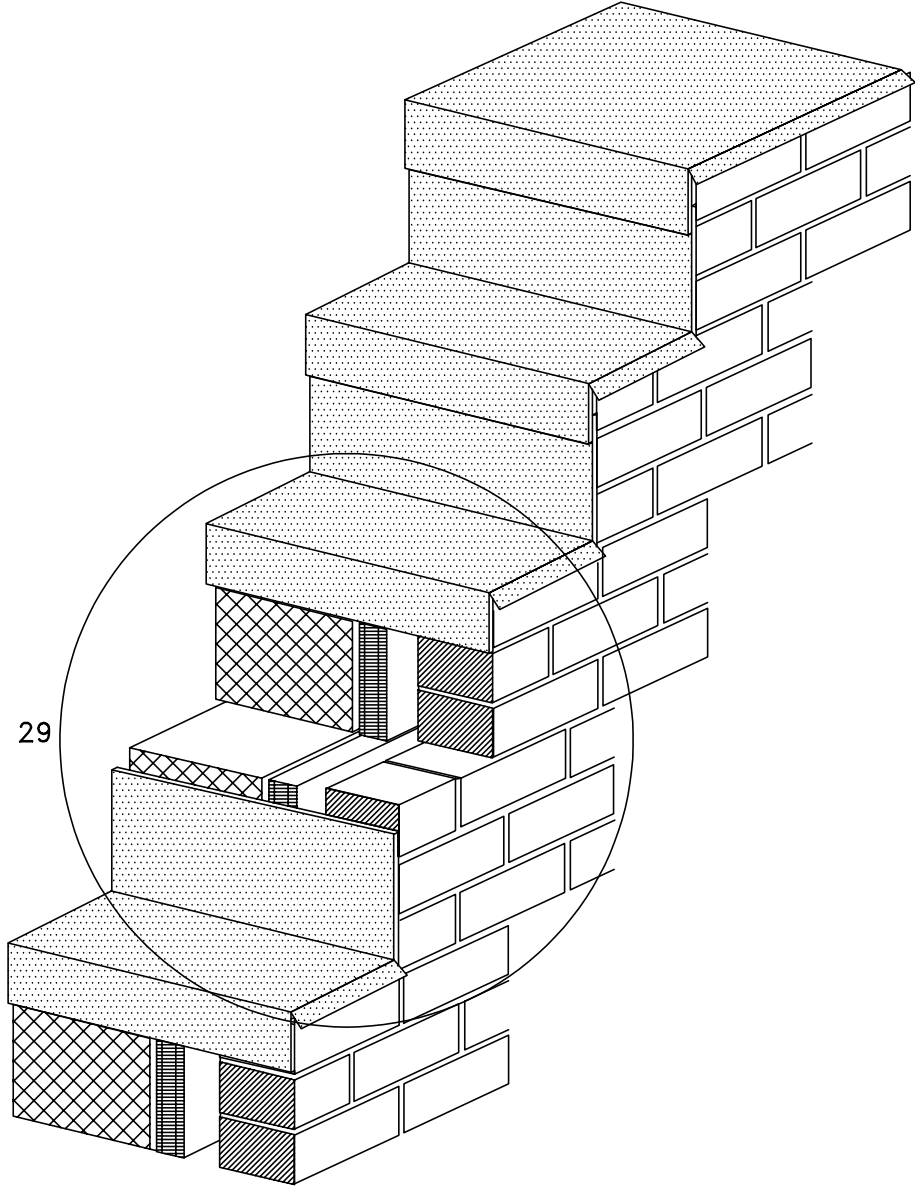

FLASHING STEPPING DOWN

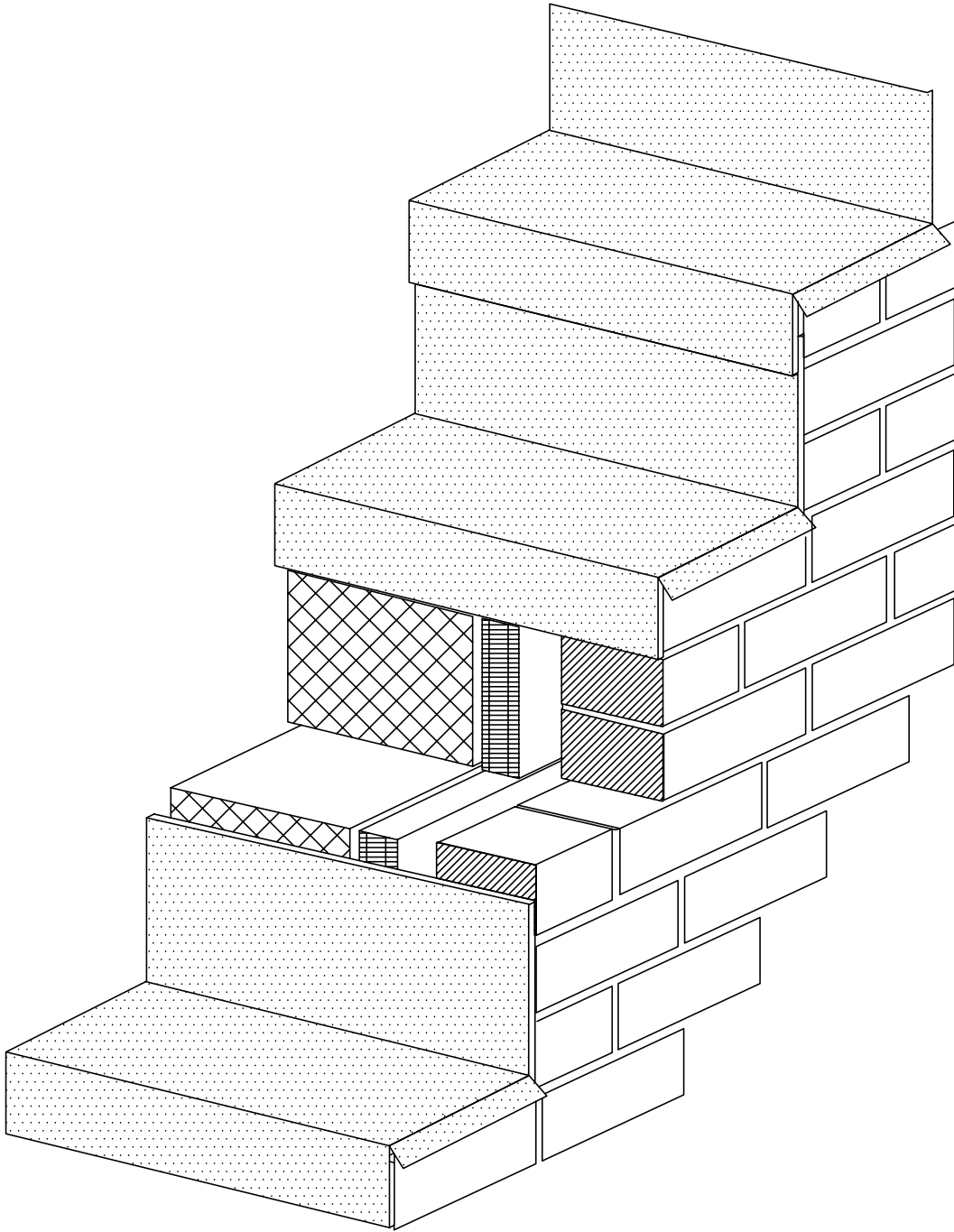

FLASHING STEPPING DOWN

1. **Three-side rod (truss-type preferred) hot-dip galvanized, 3/16" continuous joint wall reinforcing on 16" centers max., discontinuous at movement joints:** The primary function of continuous joint reinforcing is to provide transverse bond between the exterior facing wythe and the back-up wythe. The bond must be sufficient to transmit loading applied against the exterior facing wythe to the back-up wythe without cracking of the facing wythe. The presence of a continuous wire in the exterior wythe is essential to offer some resistance to thermal and moisture movements as well as to any ratchet type effect in that exterior wythe of masonry. Where clay products masonry units are utilized, they irreversibly expand due to absorption of vaporous moisture. The continuous tie/wire then acts similar to a prestressing element and provides additional restraint/stability to the system. The vertical spacing suggested for the ties corresponds to the conventional height of rigid insulation used in a typical exterior wall system. If a hollow masonry unit is used in the exterior facing wythe with face-shell bedding, then the assembly should be composed of 4 wires. Untimely ordering of such material or planned means and methods of exterior masonry installation will not supercede this requirement. Individual, tab type or adjustable reinforcement assemblies should not be allowed as a substitute for the continuous ties required.

Many Building Codes allow a 0 to 4 inch wide cavity in the exterior wall system. With a wide space between the facing and the back-up wythe, along with a close spacing of movement joints, a truss-type assembly is recommended over a ladder type to provide better stability. If appreciable movement occurs, there is a tendency for the ladder-type ties to allow a change in the plane of the exterior facing wythe at the movement joints. (See drawing titled "Truss Versus Ladder Reinforcement," Page XVII. 34) Drips or crimps should not be used on continuous ties in that they reduce the transverse bond capacity of the tie assembly. It is important, however, that the continuous ties be installed such that they slope down to the outside so that any penetrating water will not bridge the cavity via the ties. This generally means the ties should be placed after the mortar bed for the back-up wythe has been placed, but before the mortar for the facing wythe has been placed.

A continuous tie assembly is wanted because of the stability it provides to the entire exterior wall assembly with its nominal four inch wide cavity between two wythes of masonry. A hook and eye component or similar adjustable tie systems do not accomplish this need. A desirable, continuous wire in the exterior face is also lacking. The standard truss type assembly has frequently been used, both when two wythes of masonry are put up together or put up separately. With a four inch wide cavity, there is adequate play to adjust the side rod(s) when the brick wythe is laid, without bending the wire.

The continuous tie assembly spans a cavity in the exterior wall and is thus, not fully bedded in mortar. Subsequently, the hot-dipped, galvanized-after-fabrication, zinc coating needed should conform to ASTM A153 Class B2 (1.5 oz/sf). Another critical location where protection of metal should be provided is in masonry located adjacent to swimming pools. The chlorine in the water is a source for chloride ions which readily allow attack of metals in a humid environment. Reduced ventilation, such as inappropriate energy conservation measures which turn off the ventilation system at night and weekends, may aggravate this condition. Individual ties, commonly needed at the perimeter of the walls as well as around openings in the wall, should be treated like continuous ties or equivalent for protection from corrosion.

Use of prefabricated corner assemblies for the continuous wall tie system is strongly recommended. The tie assembly should also be made discontinuous in a wythe where and when movement joints occur.

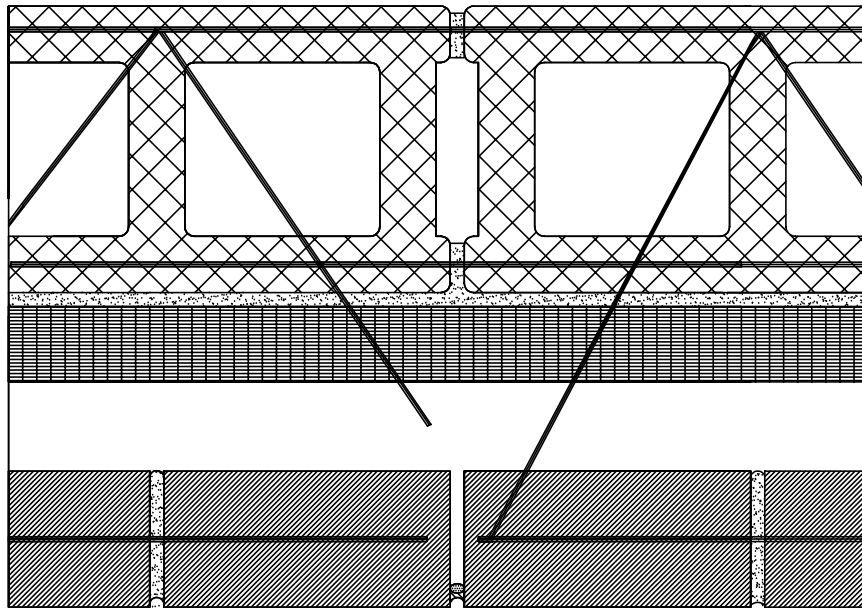

CONTINUOUS TRUSS TYPE REINFORCING

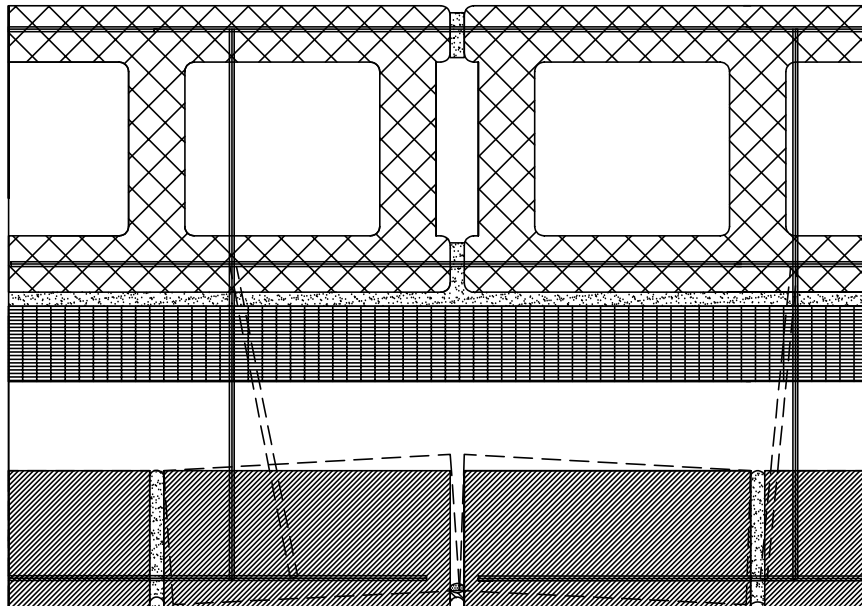

CONTINUOUS LADDER TYPE REINFORCING

NOTE: CONTINUOUS TRUSS TYPE REINFORCING SHOULD ALWAYS BE USED RATHER THEN CONTINUOUS LADDER TYPE REINFORCING, BECAUSE THE LADDER TYPE CAN HAVE A PENDULUM MOTION DURING THE MOVEMENT OF THE BRICK, WHICH MAY CAUSE MISALIGNMENT AT THE MOVEMENT JOINT.

TRUSS VERSUS LADDER REINFORCING



Transverse bonding within exterior walls using masonry headers should not be done. During the construction of such walls, the bond between header and mortar is commonly disturbed and lost in the exterior wythe on the bottom of the header unit as one face shell of the heavy concrete masonry unit in the back-up wythe is placed on top of the header unit. It is also not uncommon for the header course to tilt in and down slightly. This provides an easy path for moisture to enter the exterior wall system, bridge across the wall cavity and enter the concrete masonry back-up wythe. Such a means of transverse bonding is very brittle and subject to failure during the life of an exterior wall if any unusual stresses develop in the wall system or even if extreme thermal differences develop between facing wythe and backing wythe.

m. **Dovetail anchor slots provided in concrete frame to receive ties for masonry:** The intent is to provide a receiver for ties that are needed to provide lateral support for the masonry, at sides of columns and possibly the underside of spandrel beams. Where large areas of facing material with concrete back-up occur, ties should be used in conjunction with a continuous horizontal wire or assembly 16" on center. Where a special clip is used to allow the wire to be in the same plane as the tie, the wire and tie should be located in the same mortar joint. Where no such device is available, the continuous wire should be located in the course directly above the individual transverse ties for uniformity.

n. **Tooled, concave mortar joints on all vertical surfaces exposed to weathering:** Tooling is to intensify contact at the bond interface, densify the surface of the mortar joint and provide the appearance desired. A well-tooled, concave mortar joint will reduce the potential for water penetration and need for maintenance by providing a well-compacted mortar joint surface which makes intimate contact with the masonry units and has a slight overlap onto the face of the units, with a pleasing, uniform appearance.

### 3. **DESIGN DETAILS TO BE AVOIDED:**

a. **Dry-pack concrete trim elements:** Excessive freeze-thaw deterioration of "dry" cast, precast concrete products (commonly termed cast stone), primarily due to inadequate curing, has resulted very frequently in the past. Slate window sills, exposed to the exterior elements, have also failed prematurely. On occasion, "wet cast," architectural precast concrete products utilizing mixes with high water-cement mixes and inadequate curing techniques have also been troublesome.

b. **Common clay brick for back-up:** Excessive movement and deterioration of common clay building brick have resulted, due to chemical reactions, freeze-thaw action, as well as excessive long-term moisture expansion. Inner wythes of parapets, as well as chimney back-up, have been common causes for failure of the entire masonry element. Water penetration of masonry elements containing units with soluble sulfates allow the salts to be carried into contact with the mortar where an attack occurs resulting in a volume expansion of 227 percent as ettringite is developed. Water penetration of masonry elements containing units with unhydrated oxides allow a chemical reaction with an accompanying volume expansion of 97-118 percent as the oxides are converted to hydroxides. Use of common clay building brick in the unseen or back face of parapets continues to be a major contributor to excessive maintenance and repairs.

c. **Conventional concrete masonry exposed directly to the elements:** Without coatings which will have to be renewed, capillary water entry will cause appreciable moisture content changes of the units. Movement resulting in cracking and water penetration are likely to occur. This may cause excessive future maintenance which should be avoided whenever practical. A cementitious-type coating may then be needed. The use of concrete masonry units containing an integral waterproofing material will lower the absorption of the units and reduce such movement. It will, however, also require a similar admixture to the mortar system in the facing wythe. The life or effects of such admixtures are finite and eventually will necessitate some treatment to the exposed masonry surface. The use of such a system would also require two separate mortars to be used in the exterior wall, which could be quite an inconvenience and create numerous complications in the construction process. The use of high quality wet cast concrete products with relatively high strength and low absorption may have some merit. Water penetration is inherent, however, in all split-face masonry.

d. **Water-resistance surface treatments on exterior masonry:** The probability of successfully eliminating a preconceived moisture problem by just applying a coating are little to none. Coatings applied to exterior brick masonry, as an example, are far more likely to cause real problems than to solve anticipated problems. Coatings are not a solution for inadequate design, construction or materials. One of the few proper uses of coatings is over quality finish materials where graffiti protection is needed. The three basic types of water repellents are film formers, reactants and penetrants. Many have short lives. Appropriate surface treatments must have breathability and long term durability to respectively avoid deterioration and the need for frequent reapplication. Durability of surface treatment implies resistance to ultra-violet attack, oxidation or aging.

Assume a coating is to be applied to new masonry in order to prevent any potential moisture problems from developing in the exterior wall system. If the perceived source of the moisture is not through hairline openings at the interface between mortar and units or through the units or mortar, the coating will be a detriment. If water entry occurs from any other source or if moisture from condensation occurs, salts may be picked up and deposited behind the coating on the surface of the masonry units. If some salts recrystallize in confinement, they can produce pressures in the order of 100,000 psi. When this cryptoflorescence occurs, the forces present can cause masonry to spall or even disintegrate. In most cases, coatings are, at best, a temporary delay for solving the real problems and providing proper, long-term repairs.

Impervious coatings like epoxy can spell disaster for masonry as well as other porous associated elements. Applications of such coatings to non-vertical surfaces make them extremely vulnerable to very rapid deterioration. In summary, colorless coatings do not prevent water permeance, are short lived, and may adversely affect the durability of the masonry.

e. **Parapets:** (When such construction is needed, see “GUIDELINES FOR PARAPETS,” Page VI. 1.) They are the most weather sensitive portion of a typical exterior wall system. Beside code requirements, another potential need for parapets might be with certain types of roof construction. Roof-edge details without a parapet should be investigated first. Avoid parapets whenever possible, because of the excess maintenance too frequently associated with them. Life-cycle costing will not justify the use of parapets.

When needed, parapets should be solid and composed of the same, identical masonry units throughout to avoid disparate thermal/moisture movements and durability concerns. The use of only quality, finish materials in the parapet eliminates the need for application as well as reapplication of coatings. Neither a parapet constructed wholly or partially of conventional concrete masonry units, nor an exposed cast-in-place concrete parapet exposed both faces is acceptable. Unless a parapet is of very low height (16" or less), the back side should not be covered with a waterproof membrane or coating because of it retarding outward movement of vapor and thus trapping moisture within the parapet.

Wall cavities should not extend into parapets because of potential condensation concerns. Insulating a cavity in a parapet to totally fill it and prevent formation of condensation is nearly impossible to accomplish. Elimination of the cavity in the parapet will also reduce the width of the coping by about four inches.

Provide structural support at the roof deck (preferably top) to completely separate the parapet from the building wall below and allow for differential movement between the two masses with their different exposures. The type of roof structure utilized and its deflection characteristics may be even more of a mandate for this requirement. Where prestressed, long-span concrete elements are used, long-term creep/plastic flow of the concrete may increase camber, lifting up the parapet near mid-span. Separate, structural support for the parapet will allow for desired construction change from typical wall section to typical parapet section. This isolation of the parapet is best accomplished by use of a shelf angle or plate with the extended leg flush with the top of the roof deck/joists/spandrel or bond beam. In the event a separate support for the parapet is not appropriate, the bond must be broken at the juncture between wall and parapet or nature will randomly crack the masonry. To avoid that situation, provide a bond breaker in the bed joint of the juncture, with mortar raked back and sealant applied. With the change from wall to parapet occurring at the top of the roof structure and utilization of a low height parapet, a through-wall flashing may not be needed at that location.

Where building walls heated one side change to wing walls exposed to the elements both sides, a corresponding change in wall construction is needed vertically, which is similar to that at the horizontal juncture between wall and parapet.

f. **Outside garden, planter and wing walls:** (When such construction is absolutely necessary, see "GUIDELINES FOR EXTERIOR GARDEN, PLANTER AND WING WALLS," Page VI .1.) Without an unfrozen surface to which moisture can readily migrate, such construction in northern climates, typically, has but a five-year life expectancy. A very extensive maintenance program may be one alternative. Design may also extend the life of such construction. A rain screen wall vents the cavity to provide near equal pressure in the cavity as compared to the outside. This drastically reduces the amount of water sucked or pushed into the exterior wythe due to a pressure differential. If any other water does enter the exterior wythe, from above, behind or even below, a rain screen wall also provides two surfaces to which moisture can migrate and be dissipated. Such a wall system can tolerate even marginal masonry units and mortar subjected to an extreme environmental exposure, without experiencing major failures. (See drawing titled "Garden Wall Detail," Page XVII. 38.)

- 1. 6" REINFORCED CONCRETE
- 2. 1" AIR SPACE
- 3. BRICK

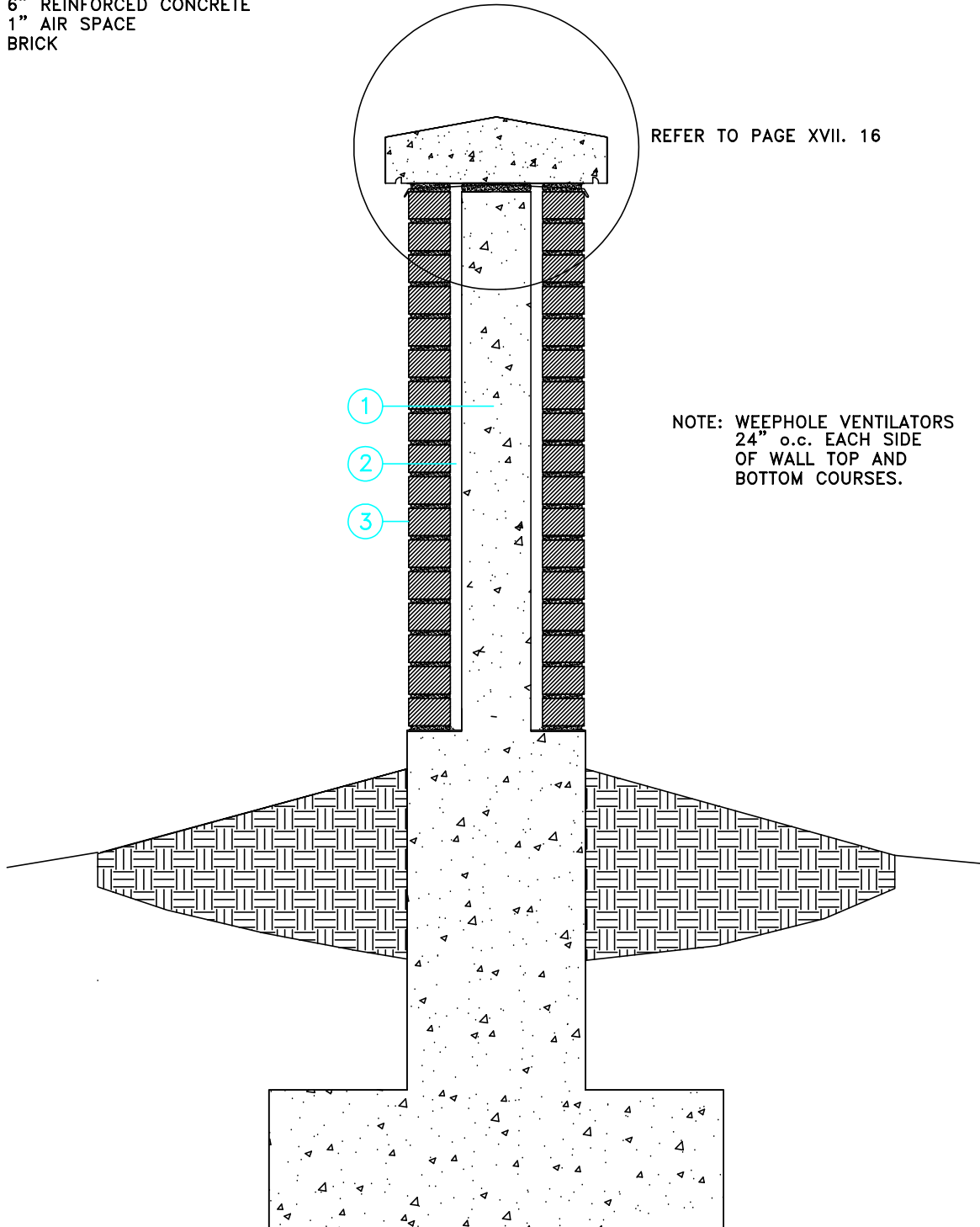

REFER TO PAGE XVII. 16

NOTE: WEEPHOLE VENTILATORS  
24" o.c. EACH SIDE  
OF WALL TOP AND  
BOTTOM COURSES.

GARDEN WALL DETAIL

Some of these same involved principles apply to other construction. If the facing of a stack or chimney is in intimate contact with either the primary structural column or a liner/back-up, then composite construction with units of different composition exists. Thermal movement alone as the stack/chimney is brought into or taken out of service will likely crack the facing. This makes it more vulnerable to moisture entry and potential freeze-thaw deterioration. If this same stack/chimney were designed and built as an uninsulated rain screen wall, the cracking would not occur, and venting would drastically reduce the stack effect over the height of the stack/chimney. This latter item would discourage water entry at the masonry unit/mortar joint interface, as well.

g. **Projections, recesses or other ornamentation in masonry without permanent wash surfaces or flashing coverings:** Rain concentrates and snow accumulates in projections and recesses. Moisture penetration from rains and melt water may lead to excessive deterioration, especially with freezing and thawing cycles likely to occur. A mortar wash is not permanent, but very short lived and therefore not acceptable. Masonry soffits with the propensity for moisture from above and within causing deterioration should not be allowed. Exotic architectural treatments will usually lead to problems requiring difficult and extensive repairs. A metal reveal in the wall system, as an example, is unacceptable due to potential water entry and resultant rust staining. Water entry as well as rust staining have too often resulted. Care must be taken to ensure that runoff from the roof is not allowed to flow over the surface of the masonry nor splashed back up upon it. Avoid creating a continuous maintenance problem. Consider future costs associated with decorative type masonry features when windows need to be replaced or roofs replaced. In correctional facilities, security may become an issue with such features.

h. **Unit masonry caps and sills:** Cast stone, brick masonry, slate, and wood caps and sills have all been associated with short term deterioration. Rowlock course, brick caps and sills are the start of periodic replacement at worst or a habitual maintenance problem at best. Use of epoxy mortar will not prevent this from happening. Even with all the exposed joints raked and caulked, moisture still penetrates and deterioration ensues. Such caulked joints will need to be recaulked on a frequent basis. In our area, the overwhelming majority of unit masonry capped, freestanding walls with letters attached being used as signs, have failed miserably in a relatively short period of time - less than five years. Typically the walls turn white at a very early age, and unless capped or otherwise treated will soon show mortar deterioration and/or unit cracking and spalling. Rather than be concerned about ways to repair such problems, prevent them from occurring in the first place. One viable alternative to a unit masonry element is an architectural precast concrete element where the masonry units are used as a facing. There is to be no mortar joint treatment, but rather an integral concrete mix and suitable vibration to final place it to the form or form lining without further treatment. More suitable for caps and sills are stone, concrete or prefinished metal elements.

i. **Soldier and header course masonry and decorative masonry panels:** The use of header course masonry has been convincingly demonstrated to be conducive to water penetration as well as uneconomical when compared to other alternatives and, thus, should not be used. The placing of conventional masonry units in a soldier course is time consuming, difficult to properly accomplish and, thus, very costly. A nominal 2 1/4 by 4 by 8 inch masonry unit is difficult enough to lay in a conventional mortar bed without some floating, let alone obtain full head joints and have all elements bonded together when done. Consider trying to lay the unit standing it on end. It wants to sink into the plastic mortar. If the mortar is not plastic, bond does not develop. How is a full head joint to be accomplished, without disturbing the previously laid unit and disrupting its bond with the adjacent unit? What if the units are to be double or triple decked in soldier course patterns? This creates even more instability. A commonly used method to overcome this instability is to place mortar behind the top of the soldier course units as laid. This is completely unacceptable in that the mortar also tends to close off the wall cavity, negating a rain screen wall. All of the above is a significantly potential problem at best and should not be done. One viable alternative to a unit masonry soldier course is the use of a manufactured masonry unit which resembles part of a soldier course but in reality is a large masonry unit of the same color and texture, containing simulated mortar joints, and of somewhat similar proportions, a nominal 8 by 4 by 16 inches in size. Prefabricated soldier course assemblages also have merit. Other alternatives include use of brick-faced, architectural precast concrete elements, masonry units of different color or texture, different materials, or even a change in masonry coursing using the same materials.

## **B. MATERIAL**

1. **Face brick:** (See “MINIMUM REQUIREMENTS FOR QUALITY OF EXTERIOR FACE BRICK MASONRY UNITS ON PROJECTS WITH MORE THAN 15,000 NEW FACE BRICK REQUIRED,” Page X. 1, “GUIDELINES FOR SELECTION OF FACE BRICK MASONRY UNITS,” Pages XI. 1-2, and “GUIDE SPECIFICATION FOR FACE BRICK MASONRY UNITS ON PROJECTS WITH MORE THAN 50,000 NEW FACE BRICK REQUIRED,” Pages XII. 1-3.)

Quality brick should last the life of the facility in which used. Some 20 percent of the face brick used in the upper Great Lakes region for exterior applications do not stand up when put to the test of an severe exposure. This, despite the fact that they meet the most stringent requirements of the current ASTM Standards. What is needed is another classification within ASTM Standards such as an “Extreme Weathering” classification for an extreme exposure. Intended would be face brick used in chimneys, retaining walls, planters, garden walls, signs, parapets, wing walls and similar such construction. An even more extreme exposure is experienced by brick located below grade, utilized as caps or sills, and projected or positioned in non-vertical surfaces. The solution is far off before a consensus approach becomes reality. In the interim, a knowledgeable specifier can require more stringent face brick requirements and/or avoid or restrict the use of the product in some applications. From the Owner's viewpoint, it is acceptable to incidentally preclude the use of a few brick which may perform well, if the restrictions imposed also exclude most of the non-performers. This problem occurs because of the overbearing concern for kiln car tonnage on the part of some brick manufacturers, a priority concern for appearance on the part of some designers, and an inadequate concern for resulting durability on the part of too many of the involved parties. As an example, do not used glazed brick for exterior applications, as the glaze typically does not adequately breathe, thus preventing the free flow of vapor through the face of the brick.

The minimum quality requirements suggested for face brick assume an extruded product, due primarily to economic considerations. This then allows a more realistic set of expectations to be imposed on the physical property requirements for face brick. The mean compressive strength of extruded brick is 11,500 psi. Many brick will meet or exceed the highest minimum strength requirements of ASTM C216 Standards (3,000 psi), after the brick are dried without ever being fired. No brick has been rejected because of the suggested minimum compressive strength requirements. Modulus of rupture relates to proper firing and extent of improper laminations and cracking. Seldom has the modulus of rupture caused rejection of a brick. The initial rate of absorption of a face brick has been used extensively as a quality control measure, does significantly determine the bond that can be achieved with conventional mortar, and will determine the practicality and ease with which a mason can lay the units in a wall. The suggested limitations for this physical property have been associated with the rejection of some face brick. Efflorescence is also associated with proper firing as well as adequate raw materials. The autoclave expansion limitation is similarly tied in with proper firing and indicates the magnitude of irreversible moisture expansion that should be expected. There are two predictors of durability, fired bond and pore structure. The latter listed alternative choices on saturation coefficient (C/B ratio), cold water absorption and pore size distribution are intended to offer leading edge of technology options to avoid involved products with a potential for freeze-thaw deterioration. Because of the minimum 70 day time required to perform a ASTM C67 Standard freeze-thaw test on the actual brick manufactured, such method is not incorporated as an option.

Storage at the site of manufacture and/or the project site after completion of firing relates to irreversible moisture expansion of fired clay products. The longer the time, the less the residual expansion left in the clay products involved. Listing of approved appearance is intended to provide the Contractor choices of at least three different vendors and manufactures, both from a physical property position as well as an economic viewpoint. Rarely is such choice not to be provided, and requires special approval if not given. Allowances are not to be used in lieu of required preselection of brick. Providing a choice to the Contractor of a vendor-offered product also places responsibility on the vendor to deliver a product from the proposed manufacturer that meets the required physical properties. Sampling and testing after the brick have been fired for a project makes great sense. If one were having a physical exam, would a previous laboratory test from several years ago be beneficial in detecting a current bout with cancer? Such checking also avoids the transportation costs of a product that might not be acceptable, thus eliminating the most significant cost currently involved in the purchase of most clay products used in this area. It is essential that the Contractor provide detailed information about the brick selected prior to requesting that the required testing after brick firing be performed, so as not to delay delivery of the brick to the project site. Information needed includes brick order, manufacturing plant location, anticipated firing completion date, etc.

As a court of last resort, it is expected that face brick for a project will be incorporated into sample panels or mock-ups, in order that their appearance requirements also pass muster, rather than create problems after the units have been incorporated into the construction involved.

The size of the brick being considered for a project may also have a significant impact on the overall cost of the exterior wall system. As an example, the cost of going from a modular standard brick (2-1/4" x 7-5/8") to a modular utility brick (3-5/8" x 11-5/8") typically would save about 20 percent of the total cost of the wall. Consideration may also be given to use of hollow brick complying with all of the requirements previously indicated, except for the cross-sectional area and minimum thickness of face shells and webs which are to comply with ASTM C652. For additions to existing facilities, it is

extremely difficult and rare to achieve an exact appearance match of new brick and mortar to that existing. Sometimes a better solution is an intentional compromise in the design.

**2. Architectural precast concrete:** (See “MINIMUM REQUIREMENTS FOR ARCHITECTURAL PRECAST CONCRETE,” Page XIII. 1.)

There have been numerous problems with architectural precast problems in the past. Fortunately, the State has not experienced any of the traumatic failures occasionally noted in the newspaper headlines. It is critical that the high quality wet cast product being discussed herein is differentiated from the lesser quality dry-pack product commonly termed cast stone, which has caused even more problems. So long as the premise that the presence of moisture and corrosion of metals are synonymous and considered in the design stages of a project, many of the potential problems with architectural precast concrete products are eliminated. Lastly is the requirement that the concrete material be designed resistant to freeze-thaw deterioration. Some extremely detailed, but possibly antiquated specification, drawing and construction check lists are available for information, if desired, to help prevent development of easily avoidable problems.

The A/E is to design the typical, architectural precast concrete element and its connections for the in-place location. All concrete cracks, but any crack through a precast unit should cause its rejection. Additional reinforcing, increase in concrete thickness, etc., for fabrication, transportation and erection is the Contractor/ Precaster's responsibility. All connections to the units are to be of a cast-in type, and avoid stress raisers. Bolted connections to permit three dimensional adjustment during erection are needed. Welding to any metal cast into precast units should not be allowed. High slump concrete may be helpful for placement of concrete but is not conducive to long term durability desired. Reinforcing bars or mesh too close to the surface of the concrete that are visible initially, will only become more noticeable as time passes. Concrete that is not adequately moist cured initially, will only be a potential problem in the future. Waterproofing should not be allowed, except where the precast units are subject to human artistry. Patch size and field-patch quantity both need definition, if either are to be allowed. Patching that is visible at the beginning, will only get worse with age and weathering.

**3. Exterior insulation and finish system:** (See “MINIMUM REQUIREMENTS FOR EXTERIOR INSULATION AND FINISH SYSTEM,” Page XIV. 1.)

An exterior insulation and finish system (EIFS) in new construction should generally be limited to use such as simulated, exposed concrete spandrels and/or columns, applied over a concrete or masonry substrate. Conversely, the application of an EIFS in retrofit of existing, older, solid exterior walls has great merit for both energy conservation as well as general restoration work.

The use of insulation applied to the interior side of existing exterior walls, especially in older buildings, has caused extensive failures as entire exterior walls are subjected to temperatures below freezing not previously experienced. As moisture in the walls tries to migrate away from a freezing zone moving inward, the moisture will be stopped at the surface of a rigid insulation, resulting in the moisture freezing causing disruption. Conversely, as internal moisture bypasses batt insulation and enters the exterior wall system by air leakage and vapor transmission, such moisture builds up as condensation or hoar frost. Subsequent freezing and thawing cycles cause deterioration.



Do not use an EIFS in other than a near-vertical position. Sill or sculptured fascia use should not even be considered, because of potential moisture build-up and resultant rapid deterioration. The purpose of these restrictions is to avoid short-lived applications which, based on past experience, will likely result in premature failures and then require extensive repairs or ongoing maintenance. Do not use EIFS as a soffit because of the propensity for moisture build-up within the soffit. Consider continuous vented aluminum soffit panels or similar methods instead.

Common EIFS cladding problems to be avoided include cracking, surface degradation, impact damage, inadequate closure and system detachment. Moisture must be kept out of the system if it is to perform on a long term basis.

A class PM (polymer modified) hard coat system with a minimum two pound density insulation is suggested to provide impact resistance and prevent damage from rough wear and tear that is expected on prominent facilities. Use armor mesh where appropriate. The use of a tongue and groove, extruded polystyrene insulation is recommended to avoid water penetration from the outside and minimize air exfiltration and vapor transmission from the inside. A combination of both mechanical and adhesive attachment is the best insurance to prevent system detachment. The insulation board should be manufactured without a skin or be abraded, and without ultraviolet surface deterioration or contaminants present at the time of installation to ensure bond and avoid system detachment. Do not allow fire resistant plywood as a backing to receive screws, nails, etc., because of the high potential such treated wood has to corrode metals on a short term basis. Movement joints must extend through the entire thickness of the system to be effective and avoid cracking. Size, location and spacing of such movement joints are of equal importance. Generally, movement joints should be located at stress raisers, placed with a length to width ratio no greater than 2.5 to 1, and creating joint-free areas no greater than 250 square feet. Movement joints should generally be constructed with a corrosive resistant metal or durable plastic surface to caulk against. Provide needed details and installation requirements as appropriate and follow through with recommendations for proper future maintenance. Whatever the exterior wall system utilized, it desirably should be for the life of the building. The jury is still out on the typical EIFS.

4. **Mortar:** (See "GUIDE SPECIFICATION FOR MORTAR," Pages XV. 1-2.)

Mortar should be expected to bind masonry units together, fill voids and make the assemblage watertight. There is much controversy over the choice of cement/lime mortars or masonry cement mortars. Suffice it to say where masonry unit/mortar bond (strength, extent and durability) is paramount, non air-entrained cement/lime mortars (2.5-4% typical entrained air content) are superior. Where freeze-thaw resistance is paramount, (such as in horizontal surfaces), masonry cement mortars or air-entrained, cement/lime mortars (11.5-12% typical entrained air content) are superior.

For the sake of consistency and to avoid confusion, it is highly preferable and much more practical that one mortar type be used for all exterior wall construction, as well as throughout the entire facility. Typically, an ASTM C270 Type "N" Cement/Lime mortar by proportion is a good all-purpose mortar, and will nearly always meet the Type "S" physical property requirements. Numerous potential problems will thus be avoided if implemented. This is but one of numerous reasons why colored mortar or admixtures should not be used. Exceptions include mortar for decorative feature stone needing white mortar, and mortar for interior glass block or glazed units. Bond beam concrete and grout for reinforced masonry should be considered as a separate entity. Mortar should always be installed as one continuous operation, rather than utilizing a setting and a pointing mortar. In the remote event that glass block are

utilized in an exterior application, a Type “S” Cement/Lime mortar is preferred for setting of the units, with all weather exposed joints raked back and treated with a sealant.

Mortar should generally be specified by proportion rather than property specifications. Too many of the desirable mortar properties are still without definition or test methods to quantify. Weaker is generally better. Testing the compressive strength of a cement/lime mortar supplied under the proportion specifications by standard methods is archaic, and will only verify strength values typically more than twice the minimum required. Current materials readily available and used in the upper Great Lakes region preclude the need for any laboratory or field testing, except in the rarest of circumstances. This is another reason why colored mortars and admixtures should not generally be used.

While there may be some initial appearance advantages why colored mortars are desirable, there are numerous reasons on a long range basis why they should not be used. In many instances, the physical properties of the mortar are adversely affected. Cost may be a consideration. Variation in proportioning, mixing or tooling will result in a mottled condition. Since all color fades in time, it is virtually impossible to match the mortar at some later point in time when the inevitable tuckpointing become necessary, as well as have the color continue to match in the distant future. If a relatively lighter, darker or less gray mortar is desired, consider preselection of material brands or sands rather than use of pigments.

It is expected that the future masonry work will more and more frequently be utilizing silo metered mortar, as a matter of choice because of convenience, uniformity and economy, over conventional job site storage and batching.

5. **Sealant:** (See “MINIMUM REQUIREMENTS FOR SEALANTS IN EXTERIOR WALLS OF NEW BUILDINGS,” Pages XVI. 1-3. and “PRE-INSTALLATION MEETING CHECK LIST FOR SEALANTS AND CAULKING,” Pages XVII. 45.)

Recent, past problems created requirements that intend to avoid the same problems in the future. One of the more frequent inadequacies with current specifications is a tendency to list all the potential sealants that might be used in a major project, but then omitting a schedule outlining where each type of sealant is to be used. During construction, a common error is not achieving proper joint configuration of the installed sealant, a rubber band effect which allows the sealant to reasonably perform. In conjunction with good sealant performance is the need for proper preparation of substrates. They must be clean, dry, sound, and free of all foreign matter, most importantly frost.

Priming should be required of all porous surfaces before the sealant is applied, to improve potential bond. Primers for porous surfaces (masonry and concrete) function in three ways. They change the chemical characteristics of the substrate, fill pores and strengthen weak areas, and/or block capillary pressure of moisture. Techniques should be utilized such that sealant thoroughly wets substrate and completely fills all voids, before tooling liquid contacts joint surface. All joints are to be tooled. Many common problems can easily be overcome by utilizing a preinstallation meeting, including observation and decision on sample installations. A mock-up of all sealant work typically needed should be required to confirm design intent, material approvals and workmanship proposed for the construction. Avoid application of sealants in locations that would create a dam or otherwise prevent water from exiting the exterior wall system.

**PRE-INSTALLATION MEETING**  
**CHECKLIST FOR SEALANTS AND CAULKING**

SECTION: 07900

1. Did you read and understand this specification section?
2. Have required samples been installed and approved?
3. Verify movement joints are all totally free of mortar and other rigid materials.
4. Clean all surfaces and clean and prime porous substrates.
5. Use closed cell, unscathed backer rod of appropriate size for joint, under slight compression.
6. Maintain proper joint configuration. (See XVI. 2.)
7. Apply sealant to dry substrate when air temperature is over 40F.
8. Gun sealant to thoroughly “wet” the substrate surface without voids.
9. How will sealant be tooled?
10. Interrupt sealant at weepholes and similar openings.

---

Installer

---

BCS

The caulking subcontractor should not be allowed on the job until all masonry movement joints in exterior masonry walls are made properly free of mortar droppings, as should have occurred when the masonry was being installed. Effectively removing mortar from joints by the caulking subcontractor just before he is applying sealant is “iffy” at best.

The leading edge of technology (along with field experience) dictate the use of polyurethanes (multicomponent suggested for larger jobs) for porous substrates and silicones for non porous substrates. Good silicones are not paintable, are electrostatic and attract dust, and will stain certain stone. Limit selection of high performance sealants for new exterior work to standard colors readily available. This is to avoid degradation of sealant material at an early age due to untried quantity or chemistry of pigments utilized in sealant manufacture. Another reason for limiting sealant color selection is to be able to reasonably match sealant as the inevitable maintenance work becomes reality, without the too common, quilt-type appearance resulting. Attack on sealant may come from atmospheric pollutants including ozone, ultraviolet radiation, moisture (rain, snow, sleet and hail), temperature changes, and movement of substrates which flex the sealant. Its life under typical exposure will be less than 20 years (commonly 5-10 years). Thus, sealant alone should not be depended upon long term, by design intent, as the sole means of preventing water penetration or air leakage.

The temperature at the time of sealant installation is a significant factor in determining if the sealant will be under more tensile or compressive stress for the remainder of its life, moderation being the best. Because of the long term irreversible expansion of fired clay products, it is suggested that the sealant be applied in movement joints of these materials during warm weather. This is to try and achieve a relatively-balanced stress condition for the sealant throughout its life.

An in-depth discussion of type of backing rod stock required is not warranted here. Once imperfections with the seal develop, water from within as well as without the envelope get to the subcaulking. If the water is absorbed by the subcaulking, it will be in contact with the sealant as well as possibly being exposed to freezing conditions. Suffice it to say that only closed cell material should be tolerated. The size of subcaulking should be approximately 25 percent larger than the size of the joint. This is to ensure a firm backing, but not overcompress the material which could rupture it or impair the resulting joint configuration. Where the use of a backing rod stock is impractical, a bond breaker is needed to ensure only two-sided joint adhesion and achieve a rubber band effect.

Some general rule of thumb are as follows. If filler is desired in movement joints during construction, only closed-cell sheet goods should be permitted. Do not use materials impregnated with oil, bitumen, non-curing polymers or similar materials as fillers or bond breakers in movement joints that are to receive sealant. All movement joints in brick masonry throughout the project should be cleaned out and made free of mortar before sealant work commences.

## C. CONSTRUCTION

### 1. CONSTRUCTION PRACTICE TO BE PROVIDED WHEN APPLICABLE:

a. **Approval of samples before starting substantial work:** (See “GUIDE SPECIFICATION FOR SAMPLE WALL/PANEL OF NEW MASONRY,” Page VII. 1, “PRE-INSTALLATION MEETING CHECK LIST FOR MASONRY IN GENERAL,” Page XVII. 48, “PRE-INSTALLATION MEETING CHECK LIST FOR INSTALLING MASONRY,” Page XVII. 49, and “PRE-INSTALLATION MEETING CHECK LIST FOR CAVITY WALL CONSTRUCTION,” Page XVII. 50.) The sample wall/panel should be an integral part of the masonry pre-installation meeting, without which the meeting is only superficial. It is imperative that all questions be raised and answered and thus potential problems be eliminated before they materialize. A good contractor is more than willing to cooperate before he invests his resources, but is extremely reluctant to participate in resolving a problem that was easily avoidable, especially after his funds for the project have already been expended. The sample which is provided should be meticulously reviewed by all parties for compliance with the contract documents prior to the formal inspection and approval. The sample also becomes the evidence to convince any judge and jury of agreed-to characteristics when the job is complete. One common cause for concern is the cleanliness of masonry. It is essential that the contractor use reasonable efforts under production techniques in providing the sample. It is equally essential for the Owner and A/E to recognize that perfection cannot be expected. To avoid complications and later disputes, the beginning stages of masonry construction should be frequently challenged as to equivalency with the workmanship and cleanliness of the approved sample.

Testing of a portion of the sample or of early construction to ensure that a true rain screen wall is being achieved, as an example, has considerable merit.

b. **Masonry laid with clean faces and faces kept clean:** (See “GUIDE SPECIFICATION FOR LAYING AND CLEANING OF NEW MASONRY,” Page IX. 1.) New masonry should be carefully laid-up, well-protected throughout the construction process and final-cleaned only where needed and by the gentlest means possible. This generally means that one or more masons will be required to stay after normal working hours are over to tool the last mortar joints laid in the day after the joints are thumb print hard, and also to remove any end of work day mortar spatters from the laying process right after they have dried. The flow of the mortar as used will contribute significantly to the ease of laying up clean masonry. Inclement weather is not conducive to laying masonry clean. The blade of the trowel should never contact the exposed face of a masonry unit to align it.

The mason can, with some effort, lay up masonry keeping its face remarkably clean. Use of water during early cleaning is usually only conducive to smearing of the mortar on the faces of the units rather than removal of excess mortar. Where construction techniques permit, the top floor of masonry should be laid before the floor below, repeating on down the wall so that no masonry work is being done over a completed wall below. Where such a technique is not practical, the completed masonry below where new masonry is being installed should be well-protected from spatter as well as the effects from the elements on the new masonry effecting the masonry below. Other means of achieving cleanliness in laying units or providing protection following laying are limited only by contractor ingenuity. Tape, wax, or other temporary face coverings are currently being evaluated for future use. Final cleaning (after 24 hours) should not normally be needed. If needed, final cleaning should only involve removal of wind blown construction dirt buildup during the construction process, without any chemical or harsh physical means.

**PRE-INSTALLATION MEETING**  
**CHECKLIST FOR MASONRY IN GENERAL**

SECTION: 04200

1. Have scaffolds been erected properly with bracing, guardrails and toe boards?
2. Are brick and other materials compared to the approved sample panel when first received?
3. Is level of workmanship received periodically compared to the approved sample?
4. Is the required exterior wall air barrier installed uninterrupted, and sealed off at the roof?
5. Are reglets for receiving flashing continuous at columns?
6. Are flashings prefabricated and with provision for field adjustment?
7. Are flashings installed without damaging them?
8. Are flashings installed down and out and with appropriate end dams and back dams?
9. Are freshly laid brick occasionally lifted and checked for bond and full joints?
10. Are walls below areas of work protected from mortar droppings?
11. Are loose metal lintels provided with void spaces at their ends?
12. Will means and methods avoid tothing of brick in all exterior walls?
13. Is closure provided to the wall at all masonry openings?
14. Are shelf angles uninterrupted at all corners?
15. Are all copings, caps and sills provided with overhangs and drips?
16. Do metal caps and covers extend over masonry a minimum of four inches?
17. Are all parapets composed of the same identical material throughout?
18. Is lateral support provided at the top of the exterior masonry back-up?
19. Are mortar joints being uniformly and timely tooled?
20. Are all weep holes clean and operable?

---

Installer

---

BCS

**PRE-INSTALLATION MEETING**  
**CHECKLIST FOR INSTALLING MASONRY**

SECTION: 04200

1. Did you read and understand this specification section?
2. Has masonry sample been approved?
3. Discuss covering materials, walls, work during construction.
4. Discuss outside temperature and how it will affect operations.
5. Will all bed and head joints be filled solid with mortar?
6. How will end-of-day mortar joints be tooled?
7. How is masonry to be cleaned and kept so?
8. Discuss keeping the control joints clean and free. (mortar, steel)
9. What type of wall reinforcing is required? (cross-section, finish)
10. What type and size flashings are to be used? (material, gauge)

---

Installer

---

BCS

**PRE-INSTALLATION MEETING**  
**CHECKLIST FOR CAVITY WALL CONSTRUCTION**

SECTION: 04200

1. Will mortar be beveled in bed joints with bricks rolled in?
2. Are bricks to be left out at supports to inspect and clean out the cavity?
3. Will a drag-board be used to help keep the cavity clean?
4. Is the insulation to be shoved into wet mortar parging and held in place by clips?
5. Are there open head joints and flashings at all masonry supports?
6. Are flashings extended out and exposed to create a drip?
7. Verify wall reinforcing and lintels do not extend through control joints.
8. Are masonry control joints in the facing and backup appropriately staggered?
9. Will wall cavity be closed off at all masonry openings?
10. Will wall cavity be sealed at corners and at roof line?

---

Installer

---

BCS



c. **Clean cavities (2" minimum preferred) in walls:** (See "GUIDE SPECIFICATION FOR CONSTRUCTION OF EXTERIOR RAIN SCREEN WALL," Pages VIII. 1-2.) Although small dimension, clean cavities are theoretically possible, a nominal 2" continuous clean air cavity in the exterior wall system between the insulation and the back of the face brick is needed to practically accomplish this objective. This will allow easy venting of the cavity as well as proper drainage, prevent mortar bridging, accommodate a board or other temporary device being placed in the cavity to keep it clean, and provide ease for the mason to grasp a facing unit and lay it in a bed of mortar without a hand contacting the parging, insulation or back-up masonry. It is quite remarkable how clean a mason can keep a 2 inch cavity when trying to do so. Back beveling of the mortar bed and minimum furrowing are paramount to accomplishment. Any mortar droppings can be removed at the base of each floor by means of the clean-out holes provided every third brick during the construction process. Flushing out the cavity with water will likely result in extensive efflorescence. There are numerous other methods and devices being used to more easily maintain a clean cavity as well as clean out the bottom of the cavity. Clean cavities are achievable as evidenced by high rise construction with inspected, grouted collar joints. The use of mesh, matting, pea gravel or other devices or material in the bottom of a cavity is not an acceptable alternate for a clean cavity and thus should not be used. The base of the wall being worked on should be cleaned out at the end of each day's work, before the mortar droppings fully harden. Brick left out for inspection/clean-cut holes should be installed just as soon as mortar is removed and the cavity is closed off by construction above, so that a reasonable mortar color match can be achieved.

d. **Movement joints in clay products masonry free of mortar:** Movement joints in clay products masonry should be kept free of mortar from the initial construction. This is to accommodate stresses otherwise created by irreversible moisture expansion of clay products, carbonation shrinkage of concrete products as well as reversible thermal and moisture movements. A final check to achieve operational movement joints is to not allow a caulker on the job site until all movement joints are cleaned out and final inspected.

e. **Caulking of movement joints in clay products masonry during warm weather:** Because of the continuing, irreversible growth of clay products masonry, the sealant should be installed in the movement joints when the masonry is thermally expanded (summertime) and the joints are at a small dimension. If this is accomplished, then the sealant is installed when the movement joints are at a predictable median dimension. This gives the best opportunity for the sealant to perform its function on a long-term basis. Delaying the sealing of movement joints in a rain screen wall should not create any concern or problems relative to water penetration.

## 2. **CONSTRUCTION PRACTICE TO BE AVOIDED:**

a. **Chemical or harsh physical cleaning of masonry:** (See "GUIDE SPECIFICATION FOR LAYING AND CLEANING OF NEW MASONRY," Page IX.1.) The guide specifications clearly outline procedures for initially laying and cleaning the masonry, and then protecting it. The guide goes on to outline a specific penalty in the event that a final cleaning using chemical or harsh physical (abrasive) means of cleaning is attempted, which is a strict violation of the contract documents. Some of the technical reasons and justification for why these requirement came into existence follow.

To begin with, if you take reasonable care and don't make a mess, you don't have to clean up. For masonry, this translates to no final cleaning. Masonry could, however, be final-cleaned in a number of ways including chemical, sand or other solid material blasting, water (with or without other material) jetting, steam, ultrasonic, water soaking, poultice, combinations of the above, or maybe the gentlest of all methods, mother nature.

Extensive large scale experiments and follow-up investigations have been done over a lengthy time period, meticulously looking at and comparing different methods of final cleaning and the resultant damage to the masonry, both long and short term, outside and inside of real buildings. None of the above final cleaning methods that are effective on new construction compares favorably with the current practice required; clean and protect as the masonry is being installed, with no final cleaning allowed.

It is necessary to comment in some detail on one of these methods of cleaning that is commonly used in the private sector, namely chemical cleaning. Any chemical capable of digesting glass, mortar or even concrete, may also introduce complex chemicals into the wall system. Such chemicals may damage the brick, will obviously damage the surface of the mortar joint or more importantly, attack the interface between mortar and the masonry unit. A typical masonry cleaner for use with newly constructed masonry is composed primarily of muriatic acid, more commonly known by its generic name of hydrochloric acid. This chemical reacting with a mortar system yields chloride ions as a by-product, the same ingredient from road salt destroying bridges and parking structures throughout the country. Even if a wall is saturated before a chemical cleaning, an acid will displace the water in any opening due to its specific gravity and thus attack the interface between masonry unit and mortar. Capillary suction at the porous, weakened interface then draws and holds water into the area with the potential for greater freeze-thaw deterioration. More critical may be the effect of an acid on any metals within the wall system. The virgin pH of typical masonry is about 12.8. If the pH is reduced significantly below 11.5, the potential for corrosion of metal exists, which is an electrochemical process. The resultant corrosion product, or rust, occupies a volume 4-5 times that of the original metal and cause internal stresses that crack open the masonry. Allowing the masonry to remain at relatively high pH levels yields a passivity that inhibits embedded metal corrosion.

The typical service life of the mortar system including its bond with the associated masonry units is significantly reduced by typical chemical cleaning. Current estimates are an instantaneous, minimum equivalent reduction of 50 to 75 years or more. A common method for analysis of mortar is by acid digestion, the dissolving of cementitious materials within a ground-up mortar sample, in a weak hydrochloric acid solution. This same material in strong concentrations is what is unconscionably being commonly used for cleaning of new masonry.

Typical chemical cleaning is the utilization of hazardous chemicals which are being haphazardly applied by the lowest skilled workers responsible to the low bid cleaning subcontractor. A common motto in the field is the stronger the acid concentration, the less the "elbow grease" needed to perform the cleaning. The Federal Environmental Protection Agency (EPA) is presently considering action which may ban current chemical cleaning practices. Harsh physical means of cleaning (also not permitted) include solid materials blasting and water jetting, which with effort can both cut through concrete.

Where touch-up of new completed masonry is needed due to inclement weather experienced or isolated accidents/carelessness, other means of localized cleaning can be utilized. A common method is the use of a stainless steel cup brush in a tuck pointing grinder. The procedure involves lightly "wiping" over

the exposed field of an individual face brick once, without intentionally contacting the adjacent mortar joints. Each such brick in the area(s) needing improvement is to be so treated.

b. **Laying masonry in winter without temporary enclosures and heat:** There are numerous references available as to recommended practices for cold weather masonry. Let it suffice to say that if free water is present and forced to undergo a change from the liquid (water) state to the solid (ice) state, a volume expansion of approximately 10 percent will occur, unless pressures in the order of 15,000 psi are available to deter such physical change. Numerous alternatives exist to avoid the potential destruction associated with such expansion/stress. The ACI 530 Masonry Code provides some general guides while the International Masonry Institute recommended practice for cold weather construction offers more specific provisions.

01/01



